



# T20 Data Sheet

---

DST20-v6.0  
November 2025  
[www.efinixinc.com](http://www.efinixinc.com)



# Contents

<b>Introduction.....</b>	<b>4</b>
<b>Features.....</b>	<b>4</b>
Available Package Options.....	5
<b>Device Core Functional Description.....</b>	<b>6</b>
XLR Cell.....	6
Logic Cell.....	7
Embedded Memory.....	7
Multipliers.....	8
Global Clock Network.....	8
Clock and Control Distribution Network.....	8
Global Clock Location (W80, Q100F3, Q144, F169, and F256).....	9
Global Clock Location (F324 and F400).....	10
<b>Device Interface Functional Description.....</b>	<b>12</b>
Interface Block Connectivity.....	12
General-Purpose I/O Logic and Buffer.....	13
Complex I/O Buffer.....	15
Double-Data I/O.....	16
I/O Banks.....	18
PLL.....	19
LVDS.....	23
LVDS TX.....	24
LVDS RX.....	26
MIPI.....	27
MIPI TX.....	28
MIPI RX.....	34
D-PHY Timing Parameters.....	39
DDR DRAM.....	41
DDR Interface Designer Settings.....	45
SPI Flash Memory.....	50
<b>Power Up Sequence.....</b>	<b>52</b>
Power Supply Current Transient.....	53
Unused Resources and Features.....	53
<b>Configuration.....</b>	<b>54</b>
Supported Configuration Modes.....	55
Mask-Programmable Memory Option.....	55
<b>DC and Switching Characteristics (W80, Q100F3, Q144, F169, and F256).....</b>	<b>56</b>
<b>DC and Switching Characteristics (F324 and F400).....</b>	<b>61</b>
<b>LVDS I/O Electrical and Timing Specifications.....</b>	<b>67</b>
<b>ESD Performance.....</b>	<b>68</b>
<b>MIPI Electrical Specifications and Timing.....</b>	<b>69</b>
MIPI Power-Up Timing.....	71
MIPI Reset Timing.....	71
<b>PLL Timing and AC Characteristics.....</b>	<b>72</b>
<b>Configuration Timing.....</b>	<b>74</b>
SPI Active.....	75
SPI Passive.....	76

JTAG.....	78
Maximum $t_{USER}$ for SPI Active and Passive Modes.....	80
<b>Pinout Description.....</b>	<b>81</b>
Pin States.....	86
<b>Efinity Software Support.....</b>	<b>87</b>
<b>T20 Interface Floorplans.....</b>	<b>88</b>
<b>Ordering Codes.....</b>	<b>93</b>
<b>Revision History.....</b>	<b>94</b>

# Introduction

The T20 FPGA features the high-density, low-power Efinix® Quantum® architecture wrapped with an I/O interface for easy integration. With a high I/O to logic ratio and differential I/O support, T20 FPGAs supports a variety of applications that need wide I/O connectivity. The T20 also includes a MIPI D-PHY with a built-in, royalty-free CSI-2 controller, which is the most popular camera interface used in the mobile industry. Additionally, T20 FPGAs support a DDR3, LPDDR3, LPDDR2 PHY with memory controller hard IP that provides faster access to data stored in memory. The carefully tailored combination of core resources and I/O provides enhanced capability for applications such as embedded vision, voice and gesture recognition, intelligent sensor hubs, power management, and LED drivers.

## Features

- High-density, low-power Quantum® architecture
- Built on SMIC 40 nm process
- Core leakage current as low as 6.8 mA<sup>(1)</sup>
- FPGA interface blocks
  - GPIO
  - PLL
  - LVDS 800 Mbps per lane with up to 20 TX pairs and 26 RX pairs
  - MIPI DPHY with CSI-2 controller hard IP, 1.5 Gbps per lane
  - DDR3, LPDDR3, LPDDR2 x16 PHY with memory controller hard IP, up to 1066 Mbps
- Programmable high-performance I/O
  - Supports 1.8, 2.5, and 3.3 V single-ended I/O standards and interfaces
- Flexible on-chip clocking
  - 16 low-skew global clock signals can be driven from off-chip external clock signals or PLL synthesized clock signals
  - PLL support
- Flexible device configuration
  - Standard SPI interface (active, passive, and daisy chain)
  - JTAG interface
  - Optional Mask Programmable Memory (MPM) capability
- Fully supported by the Efinity® software, an RTL-to-bitstream compiler

**Table 1: T20 FPGA Resources**

LEs <sup>(2)</sup>	Global Clock Networks	Global Control Networks	Embedded Memory (kbits)	Embedded Memory Blocks (5 Kbits)	Embedded Multipliers
19,728	Up to 16	Up to 16	1044.48	204	36

<sup>(1)</sup> Typical leakage current for F256 package only.

<sup>(2)</sup> Logic capacity in equivalent LE counts.

Table 2: T20 Package-Dependent Resources

Resource	W80	Q100F3	Q144	F169	F256	F324	F400
Available GPIO <sup>(3)</sup>	33	65	97	73	195	130	230
Global clocks from GPIO pins	4	4	6	4	16	5	16
Global controls from GPIO pins	4	5	8	3	16	5	16
PLLs	3	5	5	5	5	7	7
LVDS	-	4 TX pairs 4 RX pairs	6 TX pairs 6 RX pairs	8 TX pairs 12 RX pairs	13 TX pairs 13 RX pairs	20 TX pairs 26 RX pairs	20 TX pairs 26 RX pairs
MIPI DPHY with CSI-2 controller (4 data lanes, 1 clock lane)	1 TX instance 1 RX instance	-	-	2 TX instances 2 RX instances	-	2 TX instances 2 RX instances	-
DDR3/LPDDR3/ LPDDR2 PHY with memory controller	-	-	-	-	-	1 block (x8 or x16 DQ widths)	1 block (x8 or x16 DQ widths)



**Learn more:** Refer to the [Trion Packaging User Guide](#) for the package outlines and markings.

## Available Package Options

Table 3: Available Packages

Package	Dimensions (mm x mm)	Pitch (mm)
80-ball WLCSP	4.5 x 3.6	0.4
144-pin LQFP	20 x 20	0.5
100-pin LQFP	14 x 14	0.5
169-ball FBGA	9 x 9	0.65
256-ball FBGA	13 x 13	0.8
324-ball FBGA	12 x 12	0.65
400-ball FBGA	16 x 16	0.8

<sup>(3)</sup> The LVDS I/O pins are dual-purpose. The full number of GPIO are available when all LVDS I/O pins are in GPIO mode. GPIO and LVDS as GPIO supports different features. See [Table 13: Supported Features for GPIO and LVDS as GPIO](#) on page 14.

# Device Core Functional Description

T20 FPGAs feature an eXchangeable Logic and Routing (XLR) cell that Efinix has optimized for a variety of applications. Trion® FPGAs contain three building blocks constructed from XLR cells: logic elements, embedded memory blocks, and multipliers. Each FPGA in the Trion® family has a custom number of building blocks to fit specific application needs. As shown in the following figure, the FPGA includes I/O ports on all four sides, as well as columns of XLR cells, memory, and multipliers. A control block within the FPGA handles configuration.

Figure 1: T20 FPGA Block Diagram

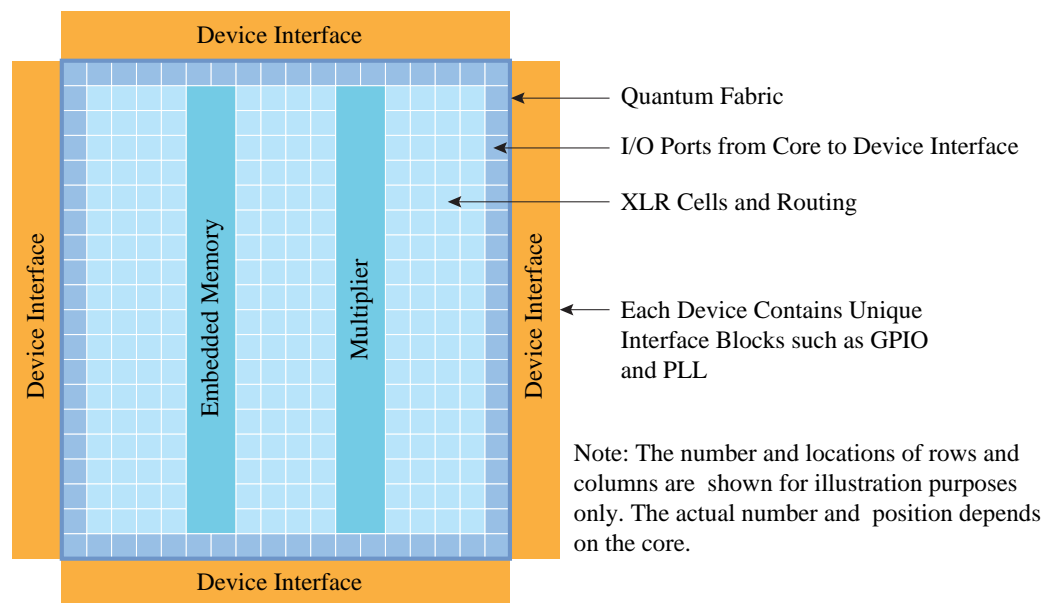

## XLR Cell

The eXchangeable Logic and Routing (XLR) cell is the basic building block of the Quantum® architecture. The Efinix XLR cell combines logic and routing and supports both functions interchangeably. This unique innovation greatly enhances the transistor flexibility and utilization rate, thereby reducing transistor counts and silicon area significantly.

## Logic Cell

The logic cell comprises a 4-input LUT or a full adder plus a register (flipflop). You can program each LUT as any combinational logic function with four inputs. You can configure multiple logic cells to implement arithmetic functions such as adders, subtractors, and counters.

Figure 2: Logic Cell Block Diagram

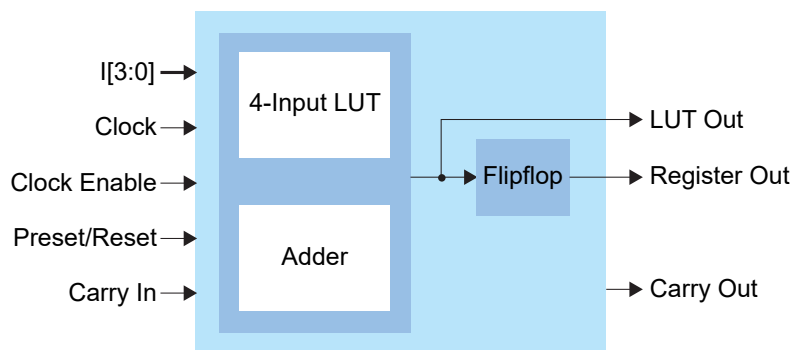

## Embedded Memory

The core has 5-kbit high-speed, synchronous, embedded SRAM memory blocks. Memory blocks can operate as single-port RAM, simple dual-port RAM, true dual-port RAM, FIFOs, or ROM. You can initialize the memory content during configuration. The Efinity<sup>®</sup> software includes a memory cascading feature to connect multiple blocks automatically to form a larger array. This feature enables you to instantiate deeper or wider memory modules.



**Note:** The block RAM content is random and undefined if it is not initialized.

The memory read and write ports have the following modes for addressing the memory (depth x width):

256 x 16	1024 x 4	4096 x 1	512 x 10
512 x 8	2048 x 2	256 x 20	1024 x 5

The read and write ports support independently configured data widths.

Figure 3: Embedded Memory Block Diagram (True Dual-Port Mode)

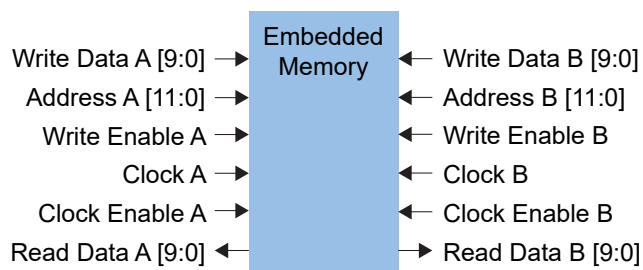

## Multipliers

The FPGA has high-performance multipliers that support 18 x 18 fixed-point multiplication. Each multiplier takes two signed 18-bit input operands and generates a signed 36-bit output product. The multiplier has optional registers on the input and output ports.

Figure 4: Multiplier Block Diagram

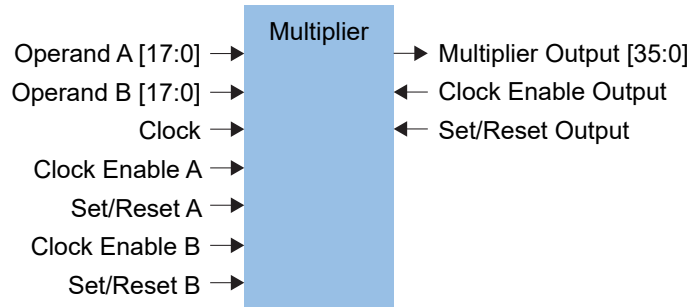

## Global Clock Network

The Quantum® core fabric supports up to 16 global clock (GCLK) signals feeding 16 pre-built global clock networks. Global clock pins (GPIO), PLL outputs, and core-generated clocks can drive the global clock network.

The global clock networks are balanced clock trees that feed all FPGA modules. Each network has dedicated clock-enable logic to save power by disabling the clock tree at the root. The logic dynamically enables/disables the network and guarantees no glitches at the output.

Figure 5: Global Clock Network

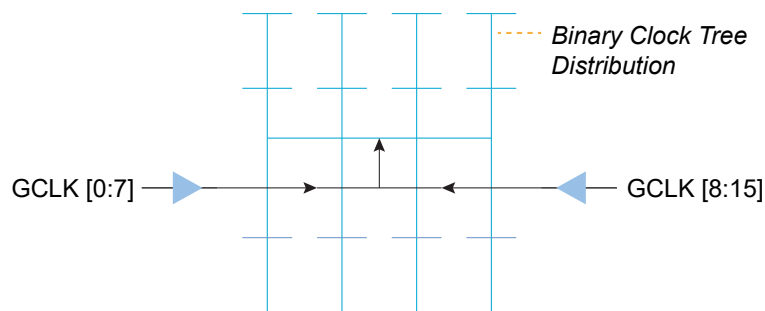

### Clock and Control Distribution Network

The global clock network is distributed through the device to provide clocking for the core's LEs, memory, multipliers, and I/O blocks. Designers can access the T20 global clock network using the global clock GPIO pins, PLL outputs, and core-generated clocks. Similarly, the T20 has GPIO pins (the number varies by package) that the designer can configure as control inputs to access the high-fanout network connected to the LE's set, reset, and clock enable signals.



**Learn more:** Refer to the [T20 Pinout](#) for information on the location and names of these pins.

## Global Clock Location (W80, Q100F3, Q144, F169, and F256)

**Table 4: Left Clock Input from GPIO Pins**

Function Name	Resource Name	GCLK[0]	GCLK[1]	GCLK[2]	GCLK[3]	GCLK[4]	GCLK[5]	GCLK[6]	GCLK[7]
CLK0	GPIOL_24	✓	-	-	-	✓	-	-	-
CLK1	GPIOL_25	-	✓	-	-	-	✓	-	-
CLK2	GPIOL_26	-	-	✓	-	-	-	✓	-
CLK3	GPIOL_27	-	-	-	✓	-	-	-	✓
CLK4	GPIOL_28	✓	-	-	-	✓	-	-	-
CLK5	GPIOL_29	-	✓	-	-	-	✓	-	-
CLK6	GPIOL_30	-	-	✓	-	-	-	✓	-
CLK7	GPIOL_31	-	-	-	✓	-	-	-	✓

**Table 5: Left Clock from PLL OUTCLK Signal**

PLL Reference	CLKOUT	GCLK[0]	GCLK[1]	GCLK[2]	GCLK[3]	GCLK[4]	GCLK[5]	GCLK[6]	GCLK[7]
PLL_TL0	CLKOUT0	✓	-	-	-	-	-	✓	-
	CLKOUT1	-	✓	✓	-	-	-	-	-
	CLKOUT2	-	✓	✓	-	-	-	-	-
PLL_TL1	CLKOUT0	-	-	-	✓	-	-	-	✓
	CLKOUT1	-	-	-	-	✓	✓	-	-
	CLKOUT2	-	-	-	-	✓	✓	-	-

**Table 6: Right Clock Input from GPIO Pins**

Function Name	Resource Name	GCLK[8]	GCLK[9]	GCLK[10]	GCLK[11]	GCLK[12]	GCLK[13]	GCLK[14]	GCLK[15]
CLK0	GPIOR_127	✓	-	-	-	✓	-	-	-
CLK1	GPIOR_126	-	✓	-	-	-	✓	-	-
CLK2	GPIOR_125	-	-	✓	-	-	-	✓	-
CLK3	GPIOR_124	-	-	-	✓	-	-	-	✓
CLK4	GPIOR_123	✓	-	-	-	✓	-	-	-
CLK5	GPIOR_122	-	✓	-	-	-	✓	-	-
CLK6	GPIOR_121	-	-	✓	-	-	-	✓	-
CLK7	GPIOR_120	-	-	-	✓	-	-	-	✓

**Table 7: Right Clock from PLL OUTCLK Signal**

PLL Reference	CLKOUT	GCLK[8]	GCLK[9]	GCLK[10]	GCLK[11]	GCLK[12]	GCLK[13]	GCLK[14]	GCLK[15]
PLL_TR0	CLKOUT0	✓	-	-	-	-	-	✓	-

PLL Reference	CLKOUT	GCLK[8]	GCLK[9]	GCLK[10]	GCLK[11]	GCLK[12]	GCLK[13]	GCLK[14]	GCLK[15]
	CLKOUT1	-	✓	✓	-	-	-	-	-
	CLKOUT2	-	✓	✓	-	-	-	-	-
PLL_TR1	CLKOUT0	-	-	-	✓	-	-	-	✓
	CLKOUT1	-	-	-	-	✓	✓	-	-
	CLKOUT2	-	-	-	-	✓	✓	-	-
PLL_BR0	CLKOUT0	✓	-	-	-	-	-	-	✓
	CLKOUT1	-	✓	✓	-	-	-	-	-
	CLKOUT2	-	✓	✓	-	-	-	-	-

### Global Clock Location (F324 and F400)

Table 8: Left Clock Input from GPIO Pins

Function Name	Resource Name	GCLK[0]	GCLK[1]	GCLK[2]	GCLK[3]	GCLK[4]	GCLK[5]	GCLK[6]	GCLK[7]
CLK0	GPIOL_66	✓	-	-	-	✓	-	-	-
CLK1	GPIOL_67	-	✓	-	-	-	✓	-	-
CLK2	GPIOL_68	-	-	✓	-	-	-	✓	-
CLK3	GPIOL_69	-	-	-	✓	-	-	-	✓
CLK4	GPIOL_70	✓	-	-	-	✓	-	-	-
CLK5	GPIOL_71	-	✓	-	-	-	✓	-	-
CLK6	GPIOL_72	-	-	✓	-	-	-	✓	-
CLK7	GPIOL_73	-	-	-	✓	-	-	-	✓

Table 9: Left Clock from PLL OUTCLK Signal

PLL Reference	CLKOUT	GCLK[0]	GCLK[1]	GCLK[2]	GCLK[3]	GCLK[4]	GCLK[5]	GCLK[6]	GCLK[7]
PLL_BL0	CLKOUT0	✓	-	-	✓	-	-	-	✓
	CLKOUT1	-	✓	-	-	✓	-	✓	-
	CLKOUT2	-	-	✓	-	-	✓	-	-

Table 10: Right Clock Input from GPIO Pins

Function Name	Resource Name	GCLK[8]	GCLK[9]	GCLK[10]	GCLK[11]	GCLK[12]	GCLK[13]	GCLK[14]	GCLK[15]
CLK0	GPIOR_133	✓	-	-	-	-	-	-	-
CLK1	GPIOR_132	-	✓	-	-	-	-	-	-
CLK2	GPIOR_131	-	-	✓	-	-	-	-	-
CLK3	GPIOR_130	-	-	-	✓	-	-	-	-
CLK4	GPIOR_129	-	-	-	-	✓	-	-	-
CLK5	GPIOR_128	-	-	-	-	-	✓	-	-
CLK6	GPIOR_127	-	-	-	-	-	-	✓	-
CLK7	GPIOR_126	-	-	-	-	-	-	-	✓

Table 11: Right Clock from PLL OUTCLK Signal

PLL Reference	CLKOUT	GCLK[8]	GCLK[9]	GCLK[10]	GCLK[11]	GCLK[12]	GCLK[13]	GCLK[14]	GCLK[15]
PLL_TR0	CLKOUT0	✓	-	-	-	-	-	✓	-
	CLKOUT1	-	✓	✓	-	-	-	-	-
	CLKOUT2	-	✓	✓	-	-	-	-	-
PLL_TR1	CLKOUT0	✓	-	-	✓	-	-	-	-
	CLKOUT1	-	-	-	-	✓	✓	-	-
	CLKOUT2	-	-	-	-	✓	✓	-	-
PLL_TR2	CLKOUT0	✓	-	-	-	-	-	-	✓
	CLKOUT1	-	✓	✓	-	-	-	-	-
	CLKOUT2	-	✓	✓	-	-	-	-	-
PLL_BR0	CLKOUT0	-	-	-	✓	-	-	-	✓
	CLKOUT1	-	-	-	-	✓	✓	-	-
	CLKOUT2	-	-	-	-	✓	✓	-	-
PLL_BR1	CLKOUT0	-	-	✓	-	-	-	✓	-
	CLKOUT1	-	-	-	✓	✓	-	-	-
	CLKOUT2	-	-	-	✓	✓	-	-	-
PLL_BR2	CLKOUT0	-	-	-	-	-	✓	-	-
	CLKOUT1	-	✓	-	-	-	-	✓	-
	CLKOUT2	-	-	-	-	-	-	-	✓

# Device Interface Functional Description

The device interface wraps the core and routes signals between the core and the device I/O pads through a signal interface. Because they use the flexible Quantum<sup>®</sup> architecture, devices in the Trion<sup>®</sup> family support a variety of interfaces to meet the needs of different applications.



**Learn more:** The following sections describe the available device interface features in T20 FPGAs. Refer to the [Trion Interfaces User Guide](#) for details on the Efinity<sup>®</sup> Interface Designer settings.

## Interface Block Connectivity

The FPGA core fabric connects to the interface blocks through a signal interface. The interface blocks then connect to the package pins. The core connects to the interface blocks using three types of signals:

- *Input*—Input data or clock to the FPGA core
- *Output*—Output from the FPGA core
- *Clock output*—Clock signal from the core clock tree

*Figure 6: Interface Block and Core Connectivity*

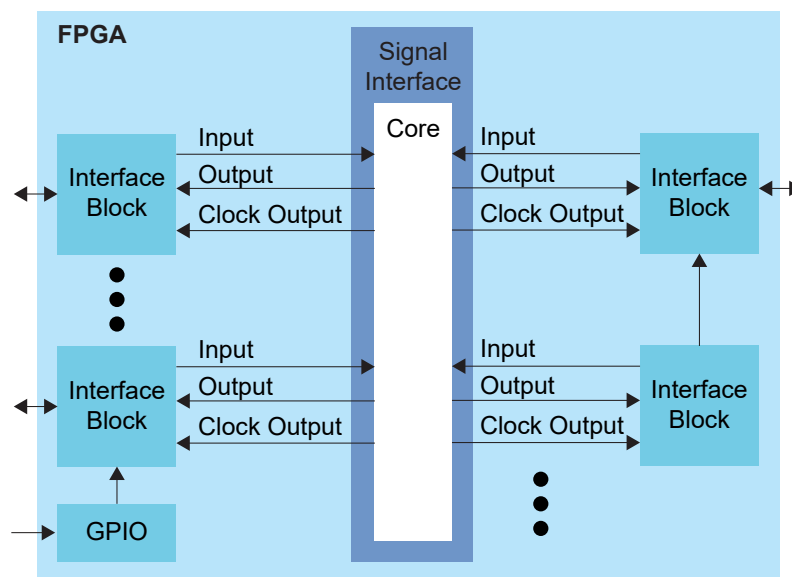

GPIO blocks are a special case because they can operate in several modes. For example, in alternate mode the GPIO signal can bypass the signal interface and directly feed another interface block. So a GPIO configured as an alternate input can be used as a PLL reference clock without going through the signal interface to the core.

When designing for Trion<sup>®</sup> FPGAs, you create an RTL design for the core and also configure the interface blocks. From the perspective of the core, outputs from the core are inputs to the interface block and inputs to the core are outputs from the interface block.

The Efinity netlist always shows signals from the perspective of the core, so some signals do not appear in the netlist:

- GPIO used as reference clocks are not present in the RTL design, they are only visible in the interface block configuration of the Efinity<sup>®</sup> Interface Designer.

- The FPGA clock tree is connected to the interface blocks directly. Therefore, clock outputs from the core to the interface are not present in the RTL design, they are only part of the interface configuration (this includes GPIO configured as output clocks).

The following sections describe the different types of interface blocks. Signals and block diagrams are shown from the perspective of the interface, not the core.

## General-Purpose I/O Logic and Buffer

The GPIO support the 3.3 V LVTTL and 1.8 V, 2.5 V, and 3.3 V LVCMOS I/O standards. The GPIOs are grouped into banks. Each bank has its own VCCIO that sets the bank voltage for the I/O standard.

Each GPIO consists of I/O logic and an I/O buffer. I/O logic connects the core logic to the I/O buffers. I/O buffers are located at the periphery of the device.

The I/O logic comprises three register types:

- *Input*—Capture interface signals from the I/O before being transferred to the core logic
- *Output*—Register signals from the core logic before being transferred to the I/O buffers
- *Output enable*—Enable and disable the I/O buffers when I/O used as output

**Table 12: GPIO Modes**

GPIO Mode	Description
Input	Only the input path is enabled; optionally registered. If registered, the input path uses the input clock to control the registers (positively or negatively triggered). Select the alternate input path to drive the alternate function of the GPIO. The alternate path cannot be registered. In DDIO mode, two registers sample the data on the positive and negative edges of the input clock, creating two data streams.
Output	Only the output path is enabled; optionally registered. If registered, the output path uses the output clock to control the registers (positively or negatively triggered). The output register can be inverted. In DDIO mode, two registers capture the data on the positive and negative edges of the output clock, multiplexing them into one data stream.
Bidirectional	The input, output, and OE paths are enabled; optionally registered. If registered, the input clock controls the input register, the output clock controls the output and OE registers. All registers can be positively or negatively triggered. Additionally, the input and output paths can be registered independently. The output register can be inverted.
Clock output	Clock output path is enabled.

**Table 13: Supported Features for GPIO and LVDS as GPIO**

LVDS as GPIO are LVDS pins that act as GPIOs instead of the LVDS function.

Package	GPIO	LVDS as GPIO
W80	DDIO Schmitt Trigger Variable Drive Strength Pull-up Pull-down Slew Rate	-
Q100F3 Q144 F169 F256	DDIO Schmitt Trigger Variable Drive Strength Pull-up Pull-down Slew Rate	Pull-up
F324 F400	DDIO Schmitt Trigger Variable Drive Strength Pull-up Pull-down Slew Rate	Variable Drive Strength Pull-up Slew Rate



**Important:** Efinix® recommends that you limit the number of LVDS as GPIO set as output and bidirectional to 16 (Q100F3, Q144, F169 and F256) or 14 (F324 and F400) per bank to avoid switching noise. The Efinity software issues a warning if you exceed the recommended limit.

## Complex I/O Buffer

Figure 7: I/O Interface Block

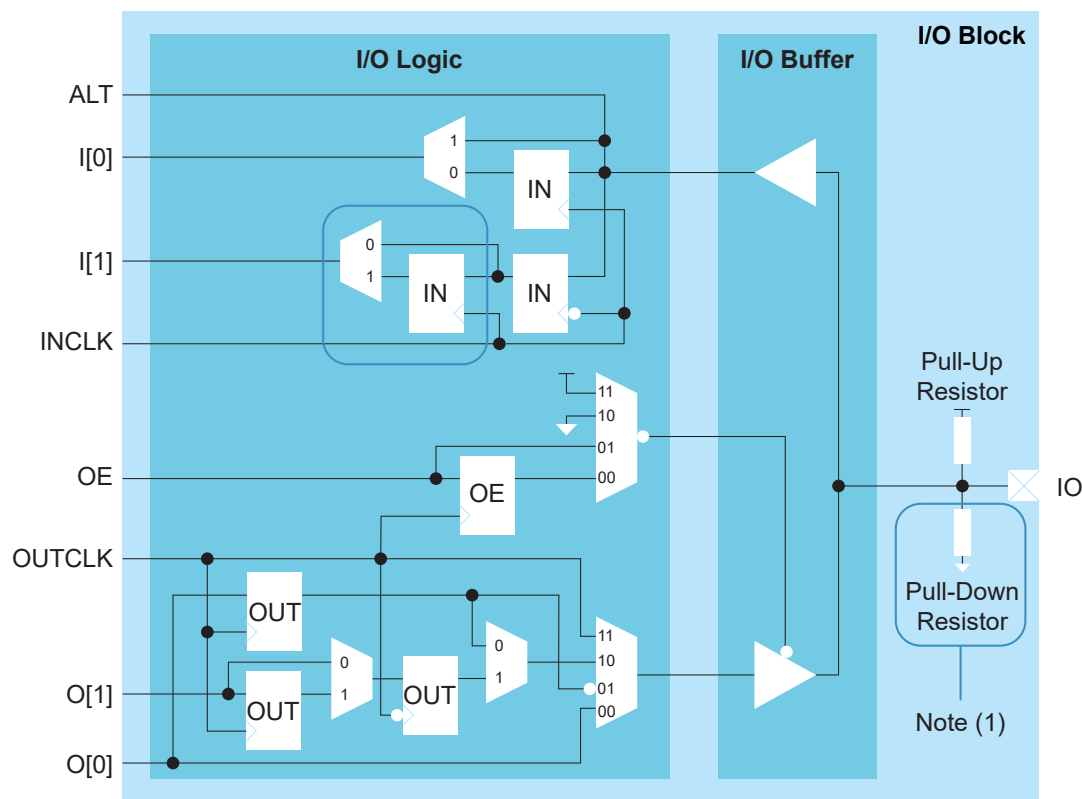

1. GPIO pins using LVDS resources do not have a pull-down resistor.



**Note:** LVDS as GPIO do not have double data I/O (DDIO).

Table 14: GPIO Signals (Interface to FPGA Fabric)

Signal	Direction	Description
I[1:0]	Output	Input data from the GPIO pad to the core fabric. I[0] is the normal input to the core. In DDIO mode, I[0] is the data captured on the positive clock edge (HI pin name in the Interface Designer) and I[1] is the data captured on the negative clock edge (LO pin name in the Interface Designer).
ALT	Output	Alternative input connection (in the Interface Designer, <b>Register Option is none</b> ). Alternative connections are GCLK, GCTRL, PLL_CLKIN, and MIPI_CLKIN. <sup>(4)</sup>
O[1:0]	Input	Output data to GPIO pad from the core fabric. O[0] is the normal output from the core. In DDIO mode, O[0] is the data output on the positive clock edge (HI pin name in the Interface Designer) and O[1] is the data output on the negative clock edge (LO pin name in the Interface Designer).
OE	Input	Output enable from core fabric to the I/O block. Can be registered.
OUTCLK	Input	Core clock that controls the output and OE registers. This clock is not visible in the user netlist unless you instantiate an EFX_GPIO_V2 primitive.
INCLK	Input	Core clock that controls the input registers. This clock is not visible in the user netlist unless you instantiate an EFX_GPIO_V2 primitive.

<sup>(4)</sup> MIPI\_CLKIN is only available in packages that support MIPI.

Table 15: GPIO Pads

Signal	Direction	Description
IO	Bidirectional	GPIO pad.

### Double-Data I/O

T20 FPGAs support double data I/O (DDIO) on certain input and output registers. In this mode, the DDIO register captures data on both positive and negative clock edges. The core receives 2 bit wide data from the interface.

In normal mode, the interface receives or sends data directly to or from the core on the positive and negative clock edges. In resync mode, the interface resynchronizes the data to pass both signals on the positive clock edge only.

Not all GPIO support DDIO; additionally, LVDS as GPIO (that is, single ended I/O) do not support DDIO functionality.



**Note:** The Resource Assigner in the Efinity® Interface Designer shows which GPIO support DDIO.

Figure 8: DDIO Input Timing Waveform

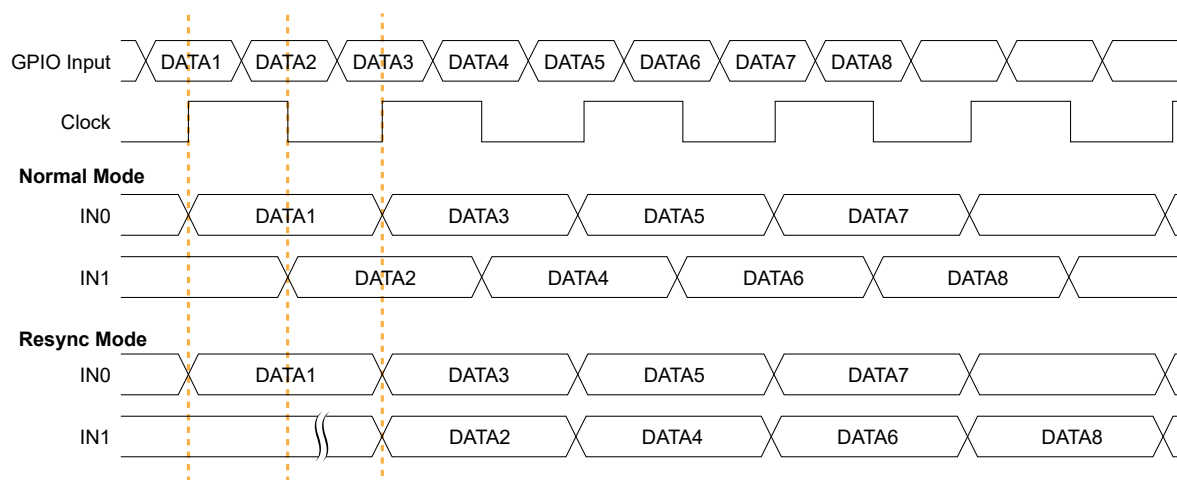

In resync mode, the IN1 data captured on the falling clock edge is delayed one half clock cycle.

In the Interface Designer, IN0 is the HI pin name and IN1 is the LO pin name.

Figure 9: DDIO Output Timing Waveform

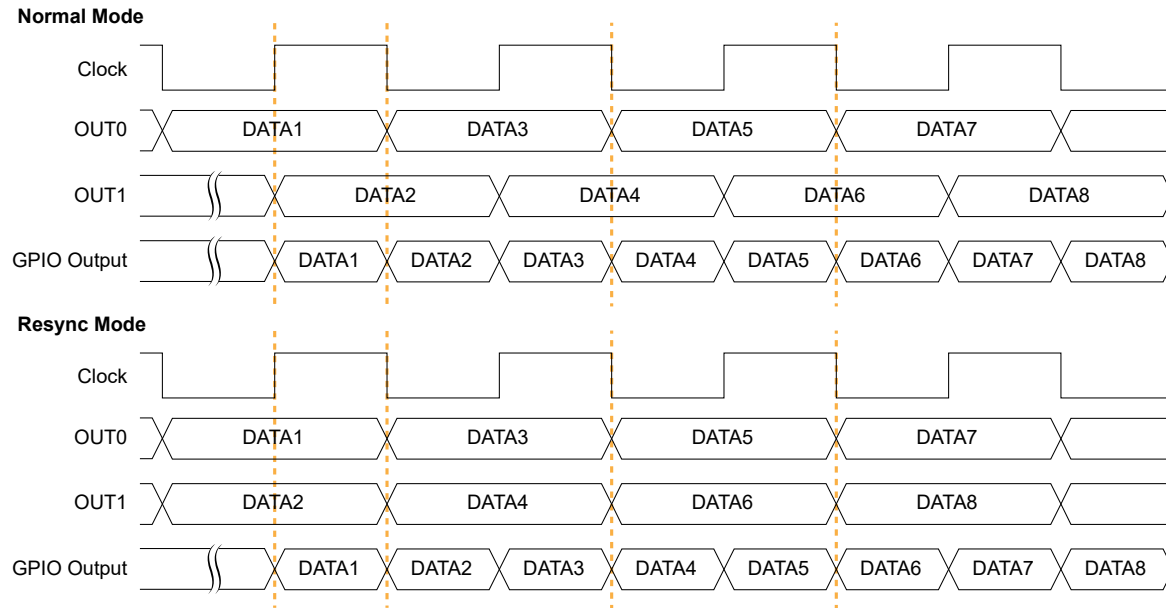

In the Interface Designer, OUT0 is the HI pin name and OUT1 is the LO pin name.

## I/O Banks

Efinix FPGAs have input/output (I/O) banks for general-purpose usage. Each I/O bank has independent power pins. The number and voltages supported vary by FPGA and package.

The number of banks and the voltages they support vary by package.

Some I/O banks are merged at the package level by sharing VCCIO pins. Merged banks have underscores ( \_ ) between banks in the name (e.g., 1B\_1C means 1B and 1C are connected).

**Table 16: I/O Banks by Package**

Package	I/O Banks	Voltage (V)	Banks with DDIO Support	Merged Banks
WP80	1A-1E, 3A-3E	1.8, 2.5, 3.3	1B, 1D, 3C, 3D, 3E	1B_1C_1D_1E, 3A_3B_3C, 3D_3E_4A_4B
Q100F3	1A - 1E, 3A - 3E	1.8, 2.5, 3.3	1B, 1C, 1D, 3B, 3C, 3D, 3E	1A_1B_1C, 1D_1E, 3B_3C, 3D_3E
	4A, 4B	3.3	-	-
Q144	1A - 1E, 3A - 3E	1.8, 2.5, 3.3	1B, 1C, 1D, 3B, 3C, 3D, 3E	1C_1D, 3B_3C
	4A, 4B	3.3	-	-
F169	1A - 1E, 3A - 3E	1.8, 2.5, 3.3	1B, 1C, 1D, 3B, 3C, 3D, 3E	1B_1C_1D, 3A_3B, 3C_3D_3E
	4A, 4B	3.3	-	-
F256	1A - 1E, 3A - 3E	1.8, 2.5, 3.3	1B, 1C, 1D, 3B, 3C, 3D, 3E	1B_1C, 1D_1E. 3A_3B_3C, 3D_3E
	4A, 4B	3.3	-	-
F324	1A - 1E, 2A - 2C, 3A - 3C, 4A, 4B, TR, BR	1.8, 2.5, 3.3	1A - 1E, 3C, TR, BR	1B_1C, 1D_1E, 3C_TR_BR
F400	1A - 1E, 2A - 2C, 3C, 4A, 4B, TR, BR	1.8, 2.5, 3.3	1A - 1E, 3C, TR, BR	3C_TR



**Learn more:** Refer to the [T20 Pinout](#) for information on the I/O bank assignments.

## PLL

The T20 has 3, 5, or 7 available PLLs (depending on the package) to synthesize clock frequencies.



**Note:** You can cascade the PLLs in T20 FPGAs. To avoid the PLL losing lock, Efinix recommends that you do not cascade more than two PLLs.

You can use the PLL to compensate for clock skew/delay via external or internal feedback to meet timing requirements in advanced application. The PLL reference clock has up to four sources. You can dynamically select the PLL reference clock with the CLKSEL port. (Hold the PLL in reset when dynamically selecting the reference clock source.)

One of the PLLs can use an LVDS RX buffer to input its reference clock.

The PLL consists of a pre-divider counter (N counter), a feedback multiplier counter (M counter), a post-divider counter (O counter), and output divider.



**Note:** Refer to [T20 Interface Floorplans](#) on page 88 for the location of the PLLs on the die. Refer to [Table 123: General Pinouts](#) on page 81 for the PLL reference clock resource assignment.

Figure 10: PLL Block Diagram

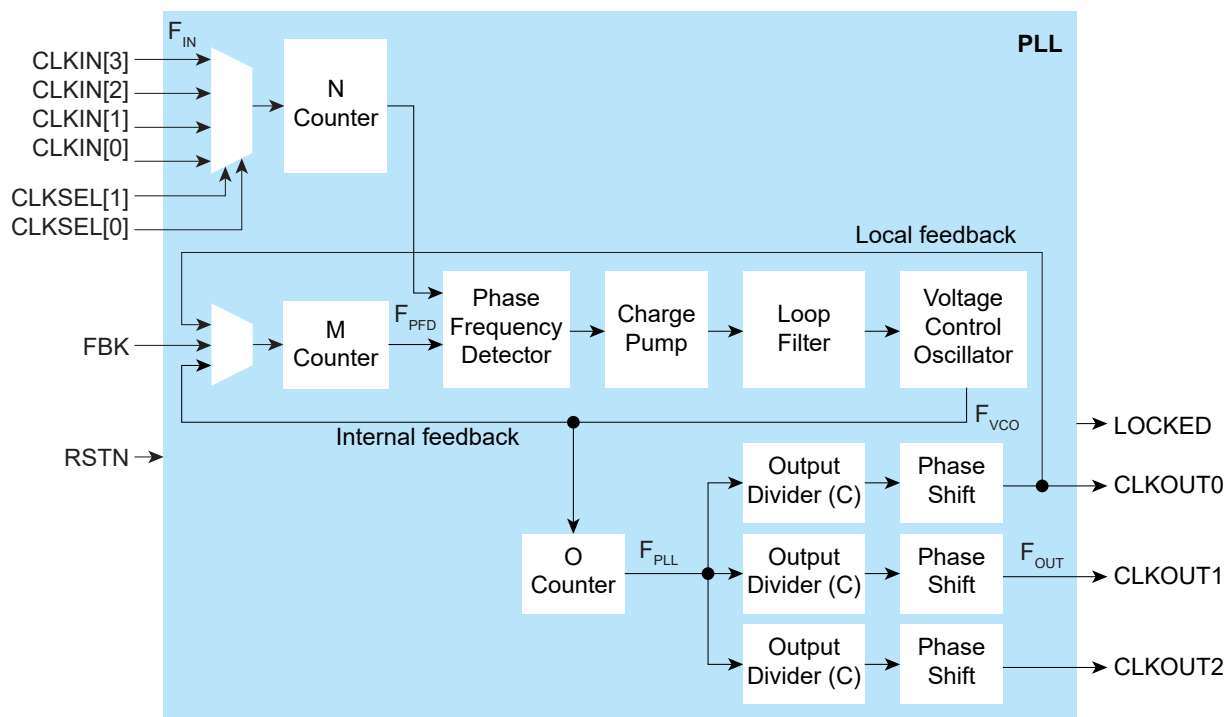

The counter settings define the PLL output frequency:

Internal Feedback Mode	Local and Core Feedback Mode	Where:
$F_{PPFD} = F_{IN} / N$ $F_{VCO} = F_{PPFD} \times M$ $F_{OUT} = (F_{IN} \times M) / (N \times O \times C)$ $F_{PLL} = F_{VCO} / O$	$F_{PPFD} = F_{IN} / N$ $F_{VCO} = (F_{PPFD} \times M \times O \times C_{FBK})^{(5)}$ $F_{OUT} = (F_{IN} \times M \times C_{FBK}) / (N \times C)$ $F_{PLL} = F_{VCO} / O$	$F_{VCO}$ is the voltage control oscillator frequency $F_{OUT}$ is the output clock frequency $F_{IN}$ is the reference clock frequency $F_{PPFD}$ is the phase frequency detector input frequency $F_{PLL}$ is the post-divider PLL frequency $C$ is the output divider $O$ is the post-divider $M$ is the multiplier $N$ is the pre-divider $C_{FBK}$ is the output divider for CLKOUT0



**Note:**  $F_{IN}$  must be within the values stated in [PLL Timing and AC Characteristics](#) on page 72.

Figure 11: PLL Interface Block Diagram

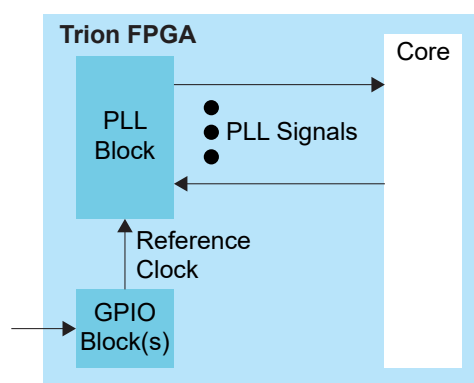

Table 17: PLL Signals (Interface to FPGA Fabric)

Signal	Direction	Description
CLKIN[3:0]	Input	Reference clocks driven by I/O pads or core clock tree.
CLKSEL[1:0]	Input	You can dynamically select the reference clock from one of the clock in pins.
RSTN	Input	Active-low PLL reset signal. When asserted, this signal resets the PLL; when de-asserted, it enables the PLL. De-assert only when the CLKIN signal is stable. Connect this signal in your design to power up or reset the PLL. Assert the RSTN pin for a minimum pulse of 10 ns to reset the PLL. Assert RSTN when dynamically changing the selected PLL reference clock.
FBK	Input	Connect to a clock out interface pin when the PLL feedback mode is not <b>internal</b> .
CLKOUT0 CLKOUT1 CLKOUT2	Output	PLL output. The designer can route these signals as input clocks to the core's GCLK network.

<sup>(5)</sup>  $(M \times O \times C_{FBK})$  must be  $\leq 255$ .

Signal	Direction	Description
LOCKED <sup>(6)</sup>	Output	Goes high when PLL achieves lock; goes low when a loss of lock is detected; remains at previous state if the CLKIN goes discontinuous. Connect this signal in your design to monitor the lock status. This signal is not synchronized to any clock and the minimum high or low pulse width of the lock signal may be smaller than the CLKOUT's period.

**Table 18: PLL Interface Designer Settings - Properties Tab**

Parameter	Choices	Notes
Instance Name	User defined	
PLL Resource		The resource listing depends on the FPGA you choose.
Clock Source	External	PLL reference clock comes from external source through the REFCLK pin. Select the available external clock.
	Dynamic	PLL reference clock comes from up to four possible sources (external and core), and are controlled by the clock select bus. Specify the clock selector and core clock names.
	Core	PLL reference clock comes from the core. Specify the core clock pin name.
Automated Clock Calculation		Pressing this button launches the PLL Clock Calculation window. The calculator helps you define PLL settings in an easy-to-use graphical interface.

<sup>(6)</sup> The circuitry that generates the lock signal relies on a reference clock edge to transition the lock signal. A sudden removal of the reference clock will result in there being no positive clock edge with which to change the lock state from 1 back to 0. Therefore, the lock signal will remain on 1.

**Table 19: PLL Interface Designer Settings - Manual Configuration Tab**

Parameter	Choices	Notes
Reset Pin Name	User defined	
Locked Pin Name	User defined	
Feedback Mode	Internal	PLL feedback is internal to the PLL resulting in no known phase relationship between clock in and clock out.
	Local	PLL feedback is local to the PLL. Aligns the clock out phase with clock in.
	Core	PLL feedback is from the core. The feedback clock is defined by the COREFBK connection, and must be one of the three PLL output clocks. Aligns the clock out phase with clock in and removes the core clock delay.
Reference clock Frequency (MHz)	User defined	
Multiplier (M)	1 - 255 (integer)	M counter.
Pre Divider (N)	1 - 15 (integer)	N counter.
Post Divider (O)	1, 2, 4, 8	O counter. The value must be 2 or higher if you enable more than 1 PLL output.
Clock 0, Clock 1, Clock 2	On, off	Use these checkboxes to enable or disable clock 0, 1, and 2.
Pin Name	User defined	Specify the pin name for clock 0, 1, or 2.
Divider (C)	1 to 256	Output divider.
Phase Shift (Degree)	0, 45, 90, 135, 180, or 270	Phase shift CLKOUT by 45°, 90°, 135°, 180°, or 270°. The phase shifts are supported with the following C divider settings: C divider = 2 : 90°, 180°, and 270° C divider = 4 : 45°, 90°, and 135° C divider = 6 : 90° To phase shift 225°, select 45° and invert the clock at the destination. To phase shift 315°, select 135° and invert the clock at the destination.
Use as Feedback	On, off	

**Table 20: PLL Reference Clock Resource Assignments (W80)**

PLL	REFCLK1	REFCLK2
PLL_TR0	GPIOR_76_PLLIN0	GPIOR_77_PLLIN1
PLL_TR1	GPIOR_76_PLLIN0	GPIOR_77_PLLIN1
PLL_TL0	GPIOL_74_PLLIN0	N/A

**Table 21: PLL Reference Clock Resource Assignments (Q100F3, Q144, F169 and F256)**

PLL	REFCLK1	REFCLK2
PLL_BR0	Differential: GPIOB_CLKP0, GPIOB_CLKN0 Single Ended: GPIOB_CLKP0	GPIOR_157_PLLIN
PLL_TR0	GPIOR_76_PLLIN0	GPIOR_77_PLLIN1
PLL_TR1	GPIOR_76_PLLIN0	GPIOR_77_PLLIN1
PLL_TL0	GPIOL_74_PLLIN0	GPIOL_75_PLLIN1
PLL_TL1	GPIOL_74_PLLIN0	GPIOL_75_PLLIN1

Table 22: PLL Reference Clock Resource Assignments (F324)

PLL	REFCLK0	REFCLK1
PLL_BL0	GPIOL_15_PLLIN0	-
PLL_BR0 <sup>(7)</sup>	GPIOR_138_PLLIN0	Single-ended: GPIOB_TXP09_CLK0
PLL_BR1	GPIOR_139_PLLIN1	Single-ended: GPIOB_TXP15_CLK1_CDI15
PLL_BR2	GPIOR_140_PLLIN2	Single-ended: GPIOB_TXP19_CLK2
PLL_TR0	GPIOR_118_PLLIN0	Differential: GPIOT_RXP08_CLKP0, GPIOT_RXN08_CLKN0 Single-ended: GPIOT_RXP08_CLKP0
PLL_TR1	GPIOR_119_PLLIN1	Differential: GPIOT_RXP17_CLKP1, GPIOT_RXN17_CLKN1 Single-ended: GPIOT_RXP17_CLKP1
PLL_TR2	GPIOR_120_PLLIN2	Differential: GPIOT_RXP25_CLKP2, GPIOT_RXN25_CLKN2 Single-ended: GPIOT_RXP25_CLKP2

Table 23: PLL Reference Clock Resource Assignments (F400)

PLL	REFCLK0	REFCLK1
PLL_BL0	GPIOL_15_PLLIN0	GPIOL_19_PLLN1
PLL_BR0 <sup>(7)</sup>	GPIOR_138_PLLIN0	Single-ended: GPIOB_TXP09_CLK0
PLL_BR1	GPIOR_139_PLLIN1	Single-ended: GPIOB_TXP15_CLK1_CDI15
PLL_BR2	GPIOR_140_PLLIN2	Single-ended: GPIOB_TXP19_CLK2
PLL_TR0	GPIOR_118_PLLIN0	Differential: GPIOT_RXP08_CLKP0, GPIOT_RXN08_CLKN0 Single-ended: GPIOT_RXP08_CLKP0
PLL_TR1	GPIOR_119_PLLIN1	Differential: GPIOT_RXP17_CLKP1, GPIOT_RXN17_CLKN1 Single-ended: GPIOT_RXP17_CLKP1
PLL_TR2	GPIOR_120_PLLIN2	Differential: GPIOT_RXP25_CLKP2, GPIOT_RXN25_CLKN2 Single-ended: GPIOT_RXP25_CLKP2

## LVDS

The LVDS hard IP transmitters and receivers operate independently.

- LVDS TX consists of LVDS transmitter and serializer logic.
- LVDS RX consists of LVDS receiver, on-die termination, and de-serializer logic.

The T20 has up to three PLLs for use with the LVDS receiver.



**Note:** You can use the LVDS TX and LVDS RX channels as 3.3 V single-ended GPIO pins, which support a weak pull-up but do not support a Schmitt trigger or variable drive strength. When using LVDS as GPIO, make sure to leave at least 2 pairs of unassigned LVDS pins between any GPIO and LVDS pins. This rule applies for pins on each side of the device (top, bottom, left, right). This separation reduces noise. The Efinity software issues an error if you do not leave this separation.

The LVDS hard IP has these features:

- Up to 800 Mbps for LVDS data transmit or receive
- Supports serialization and deserialization factors: 8:1, 7:1, 6:1, 5:1, 4:1, 3:1, and 2:1
- Ability to disable serialization and deserialization

<sup>(7)</sup> PLL\_BR0 can be used as the PHY clock for DDR DRAM block.

- Source synchronous clock output edge-aligned with data for LVDS transmitter and receiver
- 100  $\Omega$  on-die termination resistor for the LVDS receiver



**Note:** The LVDS RX supports the sub-lvds, slvs, HiVcm, RSDS and 3.3 V LVPECL differential I/O standards with a transfer rate of up to 800 Mbps.

## LVDS TX

Figure 12: LVDS TX Interface Block Diagram

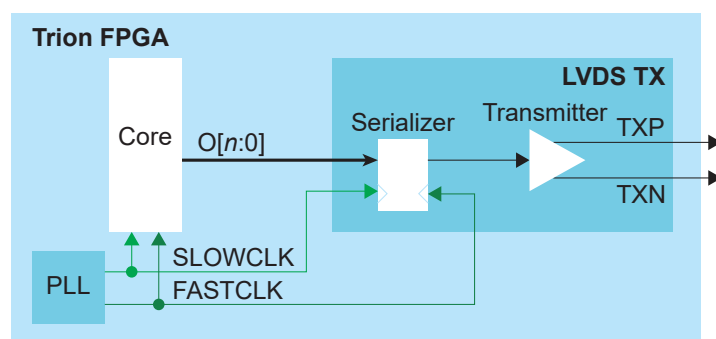

Table 24: LVDS TX Signals (Interface to FPGA Fabric)

Signal	Direction	Notes
O[n-1:0]	Input	Parallel output data where $n$ is the serialization factor. A width of 1 bypasses the serializer.
FASTCLK	Input	Fast clock to serialize the data to the LVDS pads.
SLOWCLK	Input	Slow clock to latch the incoming data from the core.

Table 25: LVDS TX Pads

Pad	Direction	Description
TXP	Output	Differential P pad.
TXN	Output	Differential N pad.



**Important:** For QFP100F3 packages, do not toggle the CCK pin when any LVDS TX is used.

The following waveform shows the relationship between the fast clock, slow clock, TX data going to the pad, and byte-aligned data from the core.

Figure 13: LVDS Timing Example Serialization Width of 8

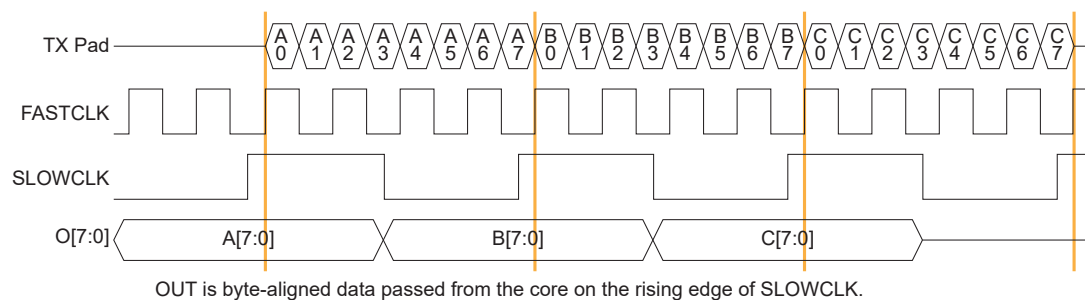

Figure 14: LVDS Timing Data and Clock Relationship Width of 8 (Parallel Clock Division=1)

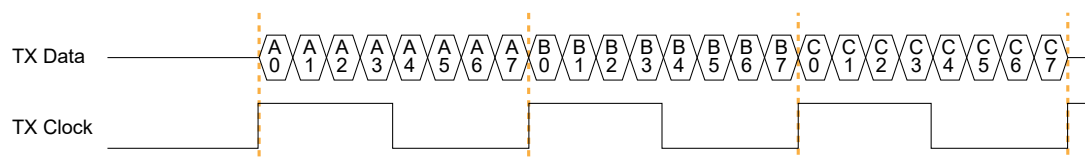
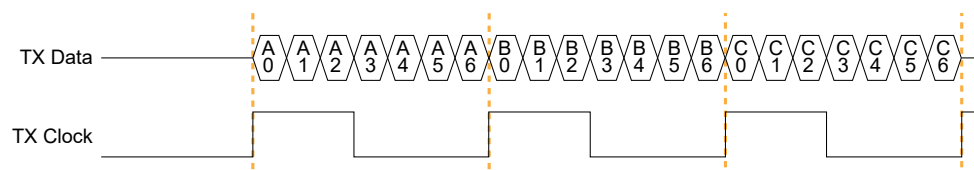

Figure 15: LVDS Timing Data and Clock Relationship Width of 7 (Parallel Clock Division=1)



**Note:** For LVDS TX interfaces with multiple LVDS TX lanes and an LVDS TX reference clock output, use the LVDS TX blocks from the same side of the FPGA to minimize skew between data lanes and TX reference clock output.

Table 26: LVDS TX Settings in Efinity® Interface Designer

Parameters	Choices	Notes
Instance Name	User defined	
LVDS Resource	Resource list	Choose a resource.
Mode	serial data output or reference clock output	<b>serial data output</b> —Simple output buffer or serialized output. <b>reference clock output</b> —Use the transmitter as a clock output. When choosing this mode, the <b>Serialization Width</b> you choose should match the serialization for the rest of the LVDS bus.
Parallel Clock Division	1, 2	<b>1</b> —The output clock from the LVDS TX lane is parallel clock frequency. <b>2</b> —The output clock from the TX lane is half of the parallel clock frequency.
Enable Serialization	On or off	When off, the serializer is bypassed and the LVDS buffer is used as a normal output.
Serialization Width	2, 3, 4, 5, 6, 7, or 8	Supports 8:1, 7:1, 6:1, 5:1, 4:1, 3:1, and 2:1. Specify the serial clock and parallel clock.
Output Pin/Bus Name	User defined	Output pin or bus that feeds the LVDS transmitter parallel data. The width should match the serialization factor.

Parameters	Choices	Notes
Output Enable Pin Name	User defined	Use with serial data output mode. Only available when serialization is disabled.
Reduce VOD Swing	On or off	When true, enables reduced output swing (similar to slow slew rate).
Output Load	<b>QFP144:</b> 5, 7, or 10 <b>All others:</b> 3, 5, 7, or 10	Output load in pF. Use an output load of 7 pF or higher to achieve the maximum supported toggle rate. See <a href="#">Table 80: Maximum Toggle Rate</a> on page 59.

## LVDS RX

Figure 16: LVDS RX Interface Block Diagram

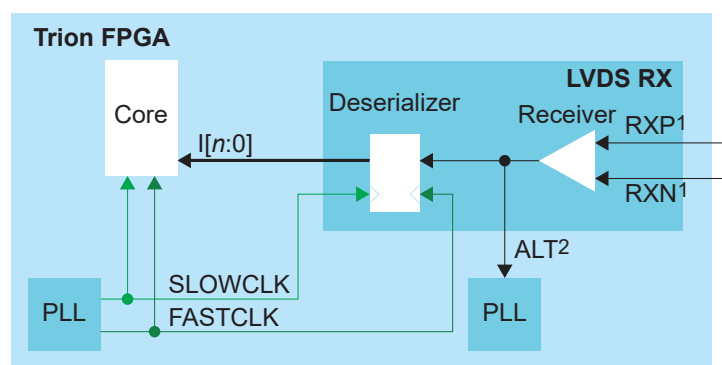

1. There is a ~30k  $\Omega$  internal weak pull-up to VCCIO (3.3V).
2. Only available for an LVDS RX resource in bypass mode (deserialization width is 1).

Table 27: LVDS RX Signals (Interface to FPGA Fabric)

Signal	Direction	Notes
I[n-1:0]	Output	Parallel input data where $n$ is the de-serialization factor. A width of 1 bypasses the deserializer.
ALT	Output	Alternative input, only available for an LVDS RX resource in bypass mode (deserialization width is 1; alternate connection type). Alternative connections are PLL_CLKIN.
FASTCLK	Input	Fast clock to de-serialize the data from the LVDS pads.
SLOWCLK	Input	Slow clock to latch the incoming data to the core.

Table 28: LVDS RX Pads

Pad	Direction	Description
RXP	Input	Differential P pad.
RXN	Input	Differential N pad.



**Note:** You need an external DC-biased circuit if the incoming LVDS signals are AC-coupled. Refer to [Trion Hardware Design Checklist and Guidelines page of the Support Center](#) for more information.

The following waveform shows the relationship between the fast clock, slow clock, RX data coming in from the pad, and byte-aligned data to the core.

Figure 17: LVDS RX Timing Example Serialization Width of 8

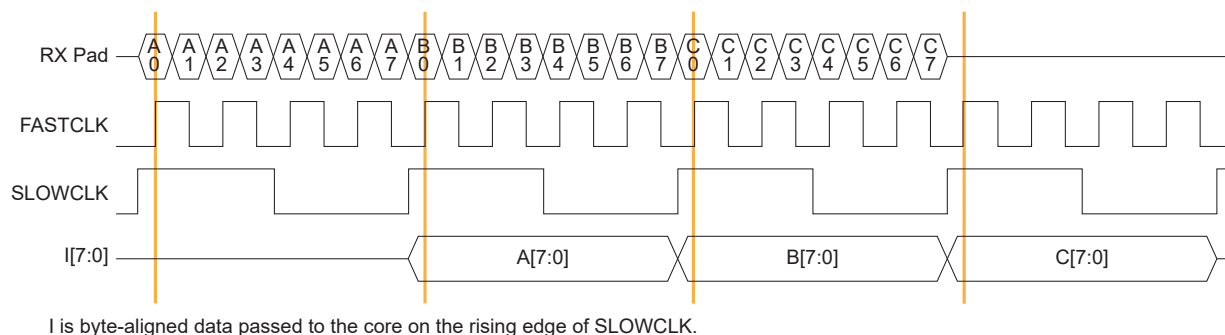

I is byte-aligned data passed to the core on the rising edge of SLOWCLK.



**Note:** For LVDS RX interfaces with multiple LVDS RX lanes and an LVDS RX clock input, use the LVDS RX blocks from the same side of the FPGA to minimize skew between data lanes and RX clock input.

Table 29: LVDS RX Settings in Efinity® Interface Designer

Parameter	Choices	Notes
Instance Name	User defined	
LVDS Resource	Resource list	Choose a resource.
Connection Type	normal, pll_clkln	<b>normal</b> —Regular RX function. <b>pll_clkln</b> —Use the PLL CLKIN alternate function of the LVDS RX resource.
Input Pin/Bus Name	User defined	Input pin or bus that feeds the LVDS transmitter parallel data. The width should match the deserialization factor.
Enable Deserialization	On or off	When off, the de-serializer is bypassed and the LVDS buffer is used as a normal input. Specify the serial clock and parallel clock.
Deserialization Width	2, 3, 4, 5, 6, 7, or 8	Supports 8:1, 7:1, 6:1, 5:1, 4:1, 3:1, and 2:1.
Enable On-Die Termination	On or off	When on, enables an on-die 100-ohm resistor.
Static Mode Delay Setting	0 - 63	Choose the amount of static delay, each step adds approximately 25 ps of delay.

## MIPI

The MIPI CSI-2 interface is the most widely used camera interface for mobile.<sup>(8)</sup> You can use this interface to build single- or multi-camera designs for a variety of applications.

T20 FPGAs include one or two (depending on the package) hardened MIPI D-PHY blocks (4 data lanes and 1 clock lane) with MIPI CSI-2 IP blocks. The MIPI RX and MIPI TX can operate independently with dedicated I/O banks.



**Note:** The MIPI D-PHY and CSI-2 controller are hard blocks; users cannot bypass the CSI-2 controller to access the D-PHY directly for non-CSI-2 applications.

<sup>(8)</sup> Source: MIPI Alliance <https://www.mipi.org/specifications/csi-2>

The MIPI TX/RX interface supports the MIPI CSI-2 specification v1.3 and the MIPI D-PHY specification v1.1. It has the following features:

- Programmable data lane configuration supporting 1, 2, or 4 lanes
- High-speed mode supports up to 1.5 Gbps data rates per lane
- Operates in continuous and non-continuous clock modes
- 64 bit pixel interface for cameras
- Supports Ultra-Low Power State (ULPS)

**Table 30: MIPI Supported Data Types**

Supported Data Type	Format
RAW	RAW6, RAW7, RAW8, RAW10, RAW12, RAW14
YUV	YUV420 8-bit (legacy), YUV420 8-bit, YUV420 10-bit, YUV420 8-bit (CSPS), YUV420 10-bit (CSPS), YUV422 8-bit, YUV422 10-bit
RGB	RGB444, RGB555, RGB565, RGB666, RGB888
User Defined	8 bit format

With more than one MIPI TX and RX blocks, Trion<sup>®</sup> FPGAs support a variety of video applications.

**Figure 18: MIPI Example System**

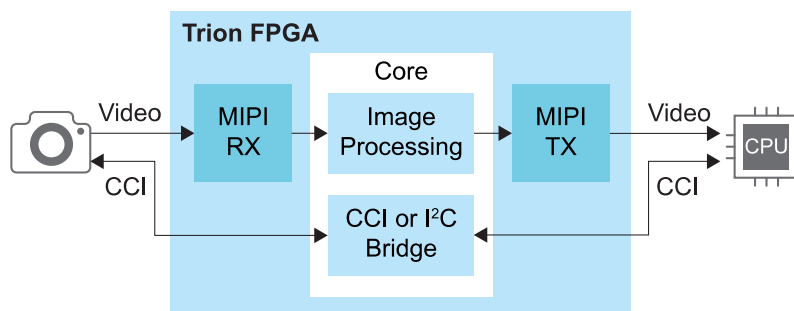

## MIPI TX

The MIPI TX is a transmitter interface that translates video data from the Trion<sup>®</sup> core into packetized data sent over the HSSI interface to the board. Five high-speed differential pin pairs (four data, one clock), each of which represent a lane, connect to the board. Control and video signals connect from the MIPI interface to the core.

Figure 19: MIPI TX x4 Block Diagram

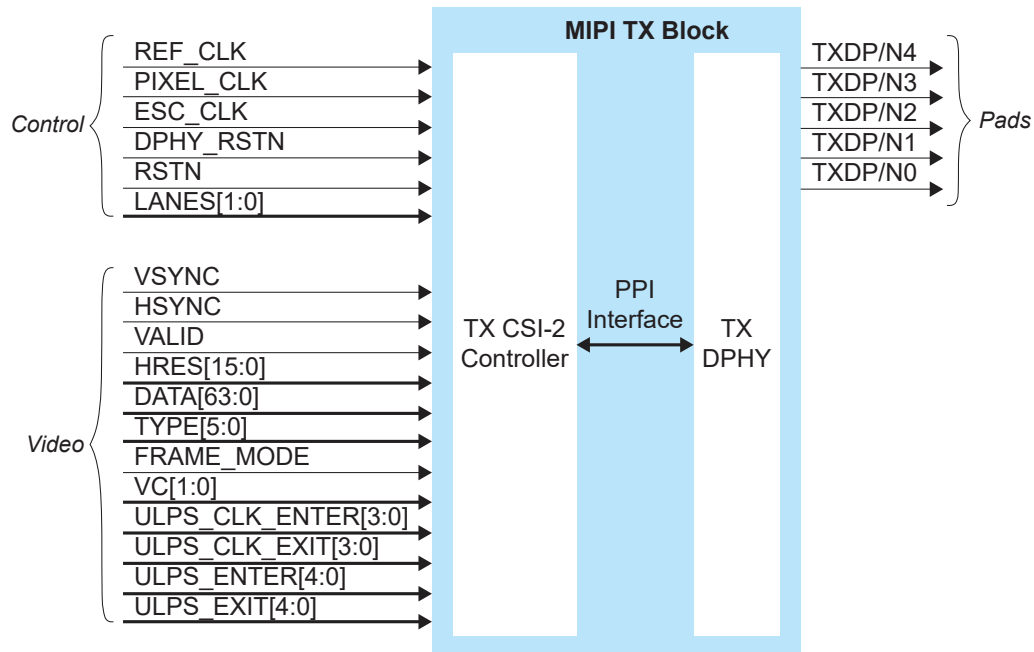

The control signals determine the clocking and how many transceiver lanes are used. All control signals are required except the two reset signals. The reset signals are optional, however, you must use both signals or neither.

The MIPI block requires an escape clock (ESC\_CLK) for use when the MIPI interface is in escape (low-power) mode, which runs between 11 and 20 MHz.



**Note:** Efinix recommends that you set the escape clock frequency as close to 20 MHz as possible.

The video signals receive the video data from the core. The MIPI interface block encodes is and sends it out through the MIPI D-PHY lanes.

Figure 20: MIPI TX Interface Block Diagram

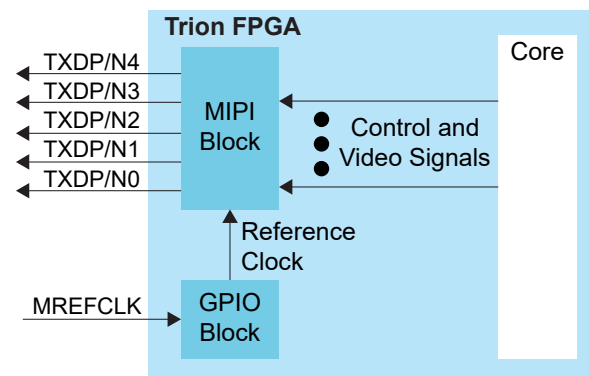

Table 31: MIPI TX Control Signals (Interface to FPGA Fabric)

Signal	Direction	Clock Domain	Description
REF_CLK	Input	N/A	Reference clock for the internal MIPI TX PLL used to generate the transmitted data. The FPGA has a dedicated GPIO resource (MREFCLK) that you must configure to provide the reference clock. All of the MIPI TX blocks share this resource. The frequency is set using Interface Designer configuration options.
PIXEL_CLK	Input	N/A	Clock used for transferring data from the core to the MIPI TX block. The frequency is based on the number of lanes and video format.
ESC_CLK	Input	N/A	Slow clock for escape mode (11 - 20 MHz).
DPHY_RSTN	Input	N/A	(Optional) Reset for the D-PHY logic, active low. Reset with the controller. See <a href="#">MIPI Reset Timing</a> .
RSTN	Input	N/A	(Optional) Reset for the CSI-2 controller logic, active low. Typically, you reset the controller with the PHY. (See <a href="#">MIPI Reset Timing</a> .) However, when dynamically changing the horizontal resolution, you only need to trigger RSTN. (See <a href="#">TX Requirements for Dynamically Changing the Horizontal Resolution</a> ).
LANES[1:0]	Input	PIXEL_CLK	Determines the number of lanes enabled. Can only be changed during reset. 00: lane 0 01: lanes 0 and 1 11: all lanes

Table 32: MIPI TX Video Signals (Interface to FPGA Fabric)

Signal	Direction	Clock Domain	Description
VSYNC	Input	PIXEL_CLK	Vertical sync.
HSYNC	Input	PIXEL_CLK	Horizontal sync.
VALID	Input	PIXEL_CLK	Valid signal.
HRES[15:0]	Input	PIXEL_CLK	Horizontal resolution. Can only be changed when VSYNC is low, and should be stable for at least one TX pixel clock cycle before VSYNC goes high.
DATA[63:0]	Input	PIXEL_CLK	Video data; the format depends on the data type. New data arrives on every pixel clock.
TYPE[5:0]	Input	PIXEL_CLK	Video data type. Can only be changed when HSYNC is low, and should be stable for at least one TX pixel clock cycle before HSYNC goes high.
FRAME_MODE	Input	PIXEL_CLK	Selects frame format. <sup>(9)</sup> 0: general frame 1: accurate frame Can only be changed during reset.
VC[1:0]	Input	PIXEL_CLK	Virtual channel (VC). Can only be changed when VSYNC is low, and should be stable at least one TX pixel clock cycle before VSYNC goes high.
ULPS_CLK_ENTER	Input	PIXEL_CLK	Place the clock lane into ULPS mode. Should not be active at the same time as ULPS_CLK_EXIT. Each high pulse should be at least 5 $\mu$ s.
ULPS_CLK_EXIT	Input	PIXEL_CLK	Remove clock lane from ULPS mode. Should not be active at the same time as ULPS_CLK_ENTER. Each high pulse should be at least 5 $\mu$ s.
ULPS_ENTER[3:0]	Input	PIXEL_CLK	Place the data lane into ULPS mode. Should not be active at the same time as ULPS_EXIT[3:0]. Each high pulse should be at least 5 $\mu$ s.
ULPS_EXIT[3:0]	Input	PIXEL_CLK	Remove the data lane from ULPS mode. Should not be active at the same time as ULPS_ENTER[3:0]. Each high pulse should be at least 5 $\mu$ s.

Table 33: MIPI TX Pads

Pad	Direction	Description
TXDP[4:0]	Output	MIPI transceiver P pads.
TXDN[4:0]	Output	MIPI transceiver N pads.

<sup>(9)</sup> Refer to the MIPI Camera Serial Interface 2 (MIPI CSI-2) for more information about frame formats.

Table 34: MIPI TX Settings in Efinity® Interface Designer

Tab	Parameter	Choices	Notes
Base	PHY Bandwidth (Mbps)	80.00 - 1500.00	Choose one of the possible PHY bandwidth values.
	Frequency (reference clock)	6, 12, 19.2, 25, 26, 27, 38.4, or 52 MHz	Reference clock frequency.
	Enable Continuous PHY Clocking	On or Off	Turns continuous clock mode on or off.
Control	Escape Clock Pin Name	User defined	
	Invert Escape Clock	On or Off	
	Pixel Clock Pin Name	User defined	
	Invert Pixel Clock	On or Off	
Lane Mapping	TXD0, TXD1, TXD2, TXD3, TXD4	clk, data0, data1, data2, or data3	Map the physical lane to a clock or data lane.
<b>Clock Timer</b>			
Timing	T <sub>CLK-POST</sub> T <sub>CLK-TRAIL</sub> T <sub>CLK-PREPARE</sub> T <sub>CLK-ZERO</sub>	Varies depending on the PHY frequency	Changes the MIPI transmitter timing parameters per the DPHY specification. Refer to <b>D-PHY Timing Parameters</b> on page 39.
	Escape Clock Frequency (MHz)	User defined	Specify a number between 11 and 20 MHz.
	T <sub>CLK-PRE</sub>	Varies depending on the escape clock frequency	Changes the MIPI transmitter timing parameters per the DPHY specification. Refer to <b>D-PHY Timing Parameters</b> on page 39.
	<b>Data Timer</b>		
	T <sub>HS-PREPARE</sub> T <sub>HS-ZERO</sub> T <sub>HS-PTRAIL</sub>	Varies depending on the PHY frequency	Changes the MIPI transmitter timing parameters per the DPHY specification. Refer to <b>D-PHY Timing Parameters</b> on page 39.

## MIPI TX Video Data TYPE[5:0] Settings

The video data type can only be changed when HSYNC is low.

Table 35: MIPI TX TYPE[5:0]

TYPE[5:0]	Data Type	Pixel Data Bits per Pixel Clock	Pixels per Clock	Bits per Pixel	Maximum Data Pixels per Line
0x20	RGB444	48	4	12	2,880
0x21	RGB555	60	4	15	2,880
0x22	RGB565	64	4	16	2,880
0x23	RGB666	54	3	18	2,556
0x24	RGB888	48	2	24	1,920
0x28	RAW6	60	10	6	7,680
0x29	RAW7	56	8	7	6,576
0x2A	RAW8	64	8	8	5,760
0x2B	RAW10	60	6	10	4,608
0x2C	RAW12	60	5	12	3,840
0x2D	RAW14	56	4	14	3,288
0x18	YUV420 8 bit	Odd line: 64 Even line: 64	Odd line: 8 Even line: 4	Odd line: 8 Even line: 8, 24	2,880
0x19	YUV420 10 bit	Odd line: 60 Even line: 40	Odd line: 6 Even line: 2	Odd line: 10 Even line: 10, 30	2,304
0x1A	Legacy YUV420 8 bit	48	4	8, 16	3,840
0x1C	YUV420 8 bit (CSPS)	Odd line: 64 Even line: 64	Odd line: 8 Even line: 4	Odd line: 8 Even line: 8, 24	2,880
0x1D	YUV420 10 bit (CSPS)	Odd line: 60 Even line: 40	Odd line: 6 Even line: 2	Odd line: 10 Even line: 10, 30	2,304
0x1E	YUV422 8 bit	64	4	8, 24	2,880
0x1F	YUV422 10 bit	40	2	10, 30	2,304
0x30 - 37	User defined 8 bit	64	8	8	5,760

## MIPI RX

The MIPI RX is a receiver interface that translates HSSI signals from the board to video data in the Trion® core. Five high-speed differential pin pairs (one clock, four data), each of which represent a lane, connect to the board. Control, video, and status signals connect from the MIPI interface to the core.

Figure 21: MIPI RX x4 Block Diagram

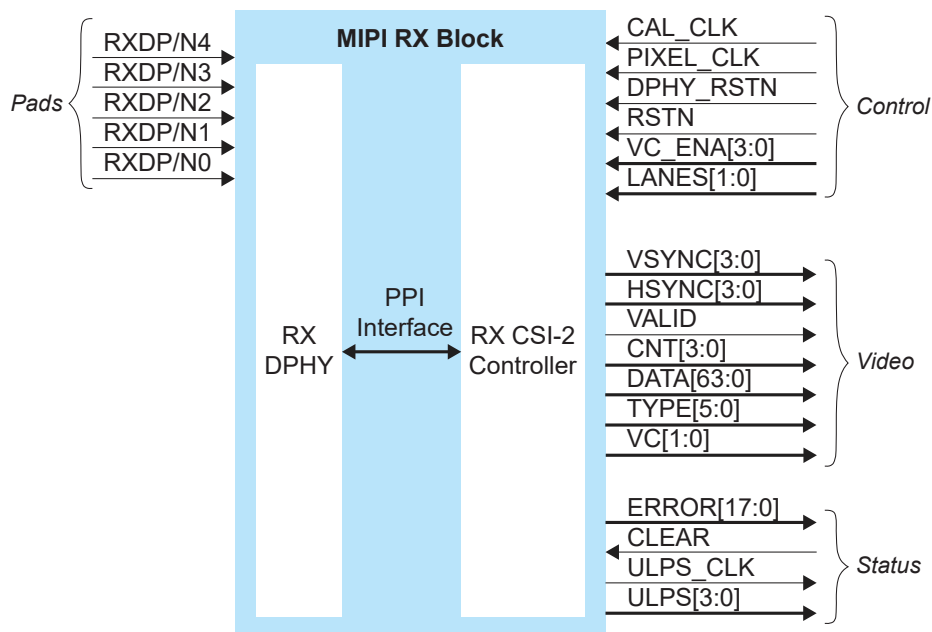

The control signals determine the clocking, how many transceiver lanes are used, and how many virtual channels are enabled. All control signals are required except the two reset signals. The reset signals are optional, however, you must use both signals or neither.

The video signals send the decoded video data to the core. All video signals must fully support the MIPI standard.

The status signals provide optional status and error information about the MIPI RX interface operation.

Figure 22: MIPI RX Interface Block Diagram

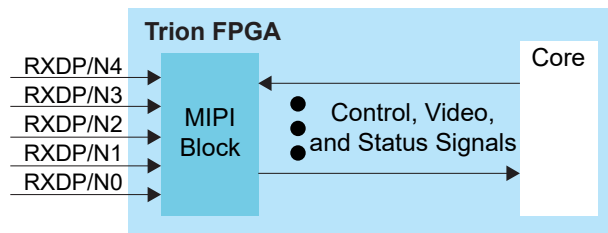

**Table 36: MIPI RX Control Signals (Interface to FPGA Fabric)**

Signal	Direction	Clock Domain	Notes
CAL_CLK	Input	N/A	Used for D-PHY calibration; must be between 80 and 120 MHz.
PIXEL_CLK	Input	N/A	Clock used for transferring data to the core from the MIPI RX block. The frequency based on the number of lanes and video format.
DPHY_RSTN	Input	N/A	(Optional) Reset for the D-PHY logic, active low. Must be used if RSTN is used. See <a href="#">MIPI Reset Timing</a> .
RSTN	Input	N/A	(Optional) Reset for the CSI-2 controller logic, active low. Must be used if DPHY_RSTN is used. See <a href="#">MIPI Reset Timing</a> .
VC_ENA[3:0]	Input	PIXEL_CLK	Enables different VC channels by setting their index high.
LANES[1:0]	Input	PIXEL_CLK	Determines the number of lanes enabled: 00: lane 0 01: lanes 0 and 1 11: all lanes Can only be set during reset.

**Table 37: MIPI RX Video Signals (Interface to FPGA Fabric)**

Signal	Direction	Clock Domain	Notes
VSYNC[3:0]	Output	PIXEL_CLK	Vsync bus. High if vsync is active for this VC.
HSYNC[3:0]	Output	PIXEL_CLK	Hsync bus. High if hsync is active for this VC
VALID	Output	PIXEL_CLK	Valid signal.
CNT[3:0]	Output	PIXEL_CLK	Number of valid pixels contained in the pixel data.
DATA[63:0]	Output	PIXEL_CLK	Video data, format depends on data type. New data every pixel clock.
TYPE[5:0]	Output	PIXEL_CLK	Video data type.
VC[1:0]	Output	PIXEL_CLK	Virtual channel (VC).

**Table 38: MIPI RX Status Signals (Interface to FPGA Fabric)**

Signal	Direction	Signal Interface	Clock Domain	Notes
ERROR[17:0]	Output	IN	PIXEL_CLK	Error bus register. Refer to <a href="#">Table 39: MIPI RX Error Signals (ERROR[17:0])</a> on page 36 for details.
CLEAR	Input	OUT	PIXEL_CLK	Reset the error registers.
ULPS_CLK	Output	IN	PIXEL_CLK	High when the clock lane is in the Ultra-Low-Power State (ULPS).
ULPS[3:0]	Output	IN	PIXEL_CLK	High when the lane is in the ULPS mode.

Table 39: MIPI RX Error Signals (ERROR[17:0])

Bit	Name	Description
0	ERR_ESC	Escape Entry Error. Asserted when an unrecognized escape entry command is received.
1	CRC_ERROR_VC0	CRC Error VC0. Set to 1 when a checksum error occurs.
2	CRC_ERROR_VC1	CRC Error VC1. Set to 1 when a checksum error occurs.
3	CRC_ERROR_VC2	CRC Error VC2. Set to 1 when a checksum error occurs.
4	CRC_ERROR_VC3	CRC Error VC3. Set to 1 when a checksum error occurs.
5	HS_RX_TIMEOUT_ERR	HS RX Timeout Error. The protocol should time out when no EoT is received within a certain period in HS RX mode.
6	ECC_1BIT_ERROR	ECC Single Bit Error. Set to 1 when there is a single bit error.
7	ECC_2BIT_ERROR	ECC 2 Bit Error. Set to 1 if there is a 2 bit error in the packet.
8	ECCBIT_ERROR	ECC Error. Asserted when an error exists in the ECC.
9	ECC_NO_ERROR	ECC No Error. Asserted when an ECC is computed with a result zero. This bit is high when the receiver is receiving data correctly.
10	FRAME_SYNC_ERROR	Frame Sync Error. Asserted when a frame end is not paired with a frame start on the same virtual channel.
11	INVLD_PKT_LEN	Invalid Packet Length. Set to 1 if there is an invalid packet length.
12	INVLD_VC	Invalid VC ID. Set to 1 if there is an invalid CSI VC ID.
13	INVALID_DATA_TYPE	Invalid Data Type. Set to 1 if the received data is invalid.
14	ERR_FRAME	Error In Frame. Asserted when VSYNC END received when CRC error is present in the data packet.
15	CONTROL_ERR	Control Error. Asserted when an incorrect line state sequence is detected.
16	SOT_ERR	Start-of-Transmission (SoT) Error. Corrupted high-speed SoT leader sequence while proper synchronization can still be achieved.
17	SOT_SYNC_ERR	SoT Synchronization Error. Corrupted high-speed SoT leader sequence while proper synchronization cannot be expected.



**Note:** If error report is all logic low, there is an EOT or a contention error. Check the physical connection of MIPI lanes or adjust the EXIT and TRAIL parameters according to the MIPI Utility.

Table 40: MIPI RX Pads

Pad	Direction	Description
RXDP[4:0]	Input	MIPI transceiver P pads.
RXDN[4:0]	Input	MIPI transceiver N pads.

Table 41: MIPI RX Settings in Efinity® Interface Designer

Tab	Parameter	Choices	Notes
Control	DPHY Calibration Clock Pin Name	User defined	
	Invert DPHY Calibration Clock	On or Off	
	Pixel Clock Pin Name	User defined	
	Invert Pixel Clock	On or Off	
Status	Enable Status	On or Off	Indicate whether you want to use the status pins.
Lane Mapping	RXD0, RXD1, RXD2, RXD3, RXD4	clk, data0, data1, data2, or data3	Map the physical lane to a clock or data lane.
	Swap P&N Pin	On or Off	Reverse the P and N pins for the physical lane.
Timing	Calibration Clock Freq (MHz)	User defined	Specify a number between 80 and 120 MHz.
	Clock Timer (T <sub>CLK-SETTLE</sub> )	40 - 2,590 ns	Changes the MIPI receiver timing parameters per the DPHY specification. Refer to <b>D-PHY Timing Parameters</b> on page 39.
	Data Timer (T <sub>HS-SETTLE</sub> )	40 - 2,590 ns	Changes the MIPI receiver timing parameters per the DPHY specification. Refer to <b>D-PHY Timing Parameters</b> on page 39.

## MIPI RX Video Data TYPE[5:0] Settings

The video data type can only be changed when HSYNC is low.

Table 42: MIPI RX TYPE[5:0]

TYPE[5:0]	Data Type	Pixel Data Bits per Pixel Clock	Pixels per Clock	Bits per Pixel	Maximum Data Pixels per Line
0x20	RGB444	48	4	12	2,880
0x21	RGB555	60	4	15	2,880
0x22	RGB565	64	4	16	2,880
0x23	RGB666	54	3	18	2,556
0x24	RGB888	48	2	24	1,920
0x28	RAW6	48	8	6	7,680
0x29	RAW7	56	8	7	6,576
0x2A	RAW8	64	8	8	5,760
0x2B	RAW10	40	4	10	4,608
0x2C	RAW12	48	4	12	3,840
0x2D	RAW14	56	4	14	3,288
0x18	YUV420 8 bit	Odd line: 64 Even line: 64	Odd line: 8 Even line: 4	Odd line: 8 Even line: 8, 24	2,880
0x19	YUV420 10 bit	Odd line: 40 Even line: 40	Odd line: 4 Even line: 2	Odd line: 10 Even line: 10, 30	2,304
0x1A	Legacy YUV420 8 bit	48	4	8, 16	3,840
0x1C	YUV420 8 bit (CSPS)	Odd line: 64 Even line: 64	Odd line: 8 Even line: 4	Odd line: 8 Even line: 8, 24	2,880
0x1D	YUV420 10 bit (CSPS)	Odd line: 40 Even line: 40	Odd line: 4 Even line: 2	Odd line: 10 Even line: 10, 30	2,304
0x1E	YUV422 8 bit	64	4	8, 24	2,880
0x1F	YUV422 10 bit	40	2	10, 30	2,304
0x30 - 37	User defined 8 bit	64	8	8	5,760

## D-PHY Timing Parameters

During CSI-2 data transmission, the MIPI D-PHY alternates between low power mode and high-speed mode. The D-PHY specification defines timing parameters to facilitate the correct hand-shaking between the MIPI TX and MIPI RX during mode transitions.

You set the timing parameters to correspond to the specifications of your hardware in the Efinity® Interface Designer.

- *RX parameters*— $T_{CLK-SETTLE}$ ,  $T_{HS-SETTLE}$  (see **Table 36: MIPI RX Control Signals (Interface to FPGA Fabric)** on page 35)
- *TX parameters*— $T_{CLK-POST}$ ,  $T_{CLK-TRAIL}$ ,  $T_{CLK-PREPARE}$ ,  $T_{CLK-ZERO}$ ,  $T_{CLK-PRE}$ ,  $T_{HS-PREPARE}$ ,  $T_{HS-ZERO}$ ,  $T_{HS-TRAIL}$  (see **Table 34: MIPI TX Settings in Efinity Interface Designer** on page 32)

Figure 23: High-Speed Data Transmission in Bursts Waveform

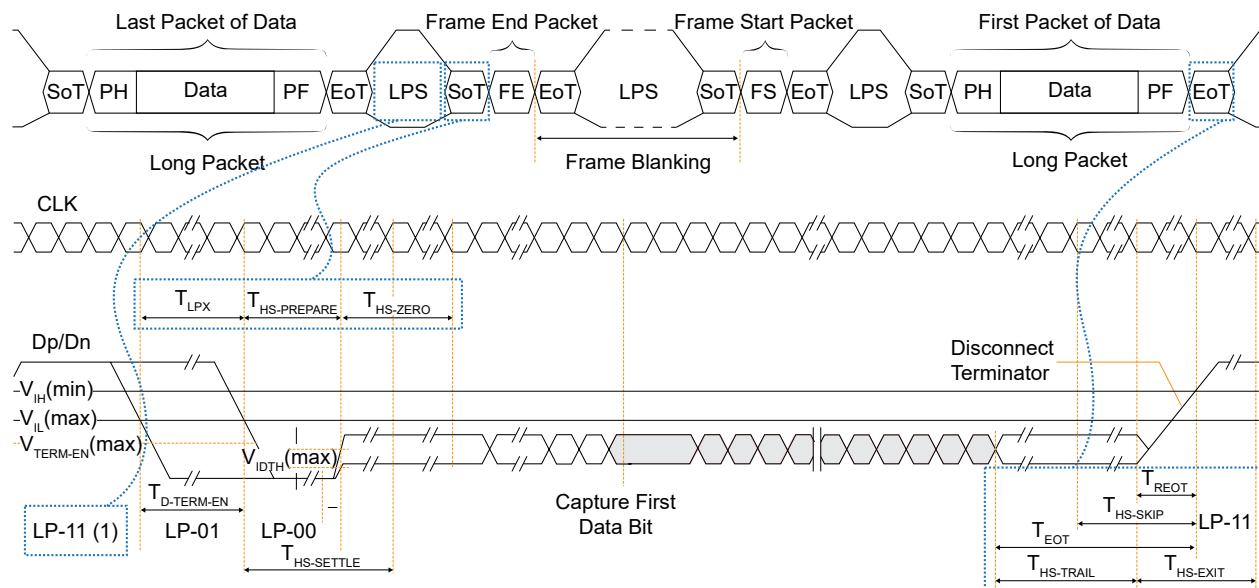

Note:

1. To enter high-speed mode, the D-PHY goes through states LP-11, LP-01, and LP-00. The D-PHY generates LP-11 to exit high-speed mode.

Figure 24: Switching the Clock Lane between Clock Transmission and Low Power Mode Waveform

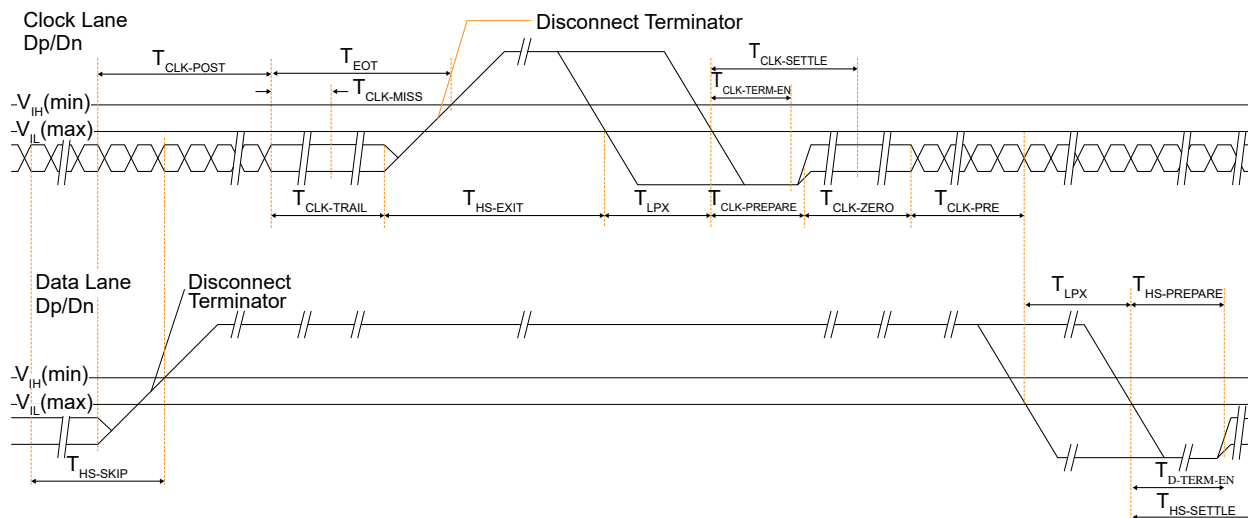

Table 43: D-PHY Timing Specifications

Parameter	Description	Min	Typ	Max	Unit
$T_{CLK-POST}$	Time that the transmitter continues to send HS clock after the last associated Data Lane has transitioned to LP Mode. Interval is defined as the period from the end of $T_{HS-TRAIL}$ to the beginning of $T_{CLK-TRAIL}$ .	$60\text{ ns} + 52*UI$	-	-	ns
$T_{CLK-PRE}$	Time that the HS clock shall be driven by the transmitter prior to any associated Data Lane beginning the transition from LP to HS mode.	8	-	-	UI
$T_{CLK-PREPARE}$	Time that the transmitter drives the Clock Lane LP-00 Line state immediately before the HS-0 Line state starting the HS transmission.	38	-	95	ns
$T_{CLK-SETTLE}$	Time interval during which the HS receiver should ignore any Clock Lane HS transitions, starting from the beginning of $T_{CLK-PREPARE}$ .	95	-	300	ns
$T_{CLK-TRAIL}$	Time that the transmitter drives the HS-0 state after the last payload clock bit of a HS transmission burst.	60	-	-	ns
$T_{CLK-PREPARE} + T_{CLK-ZERO}$	$T_{CLK-PREPARE}$ + time that the transmitter drives the HS-0 state prior to starting the Clock.	300	-	-	ns
$T_{HS-PREPARE}$	Time that the transmitter drives the Data Lane LP-00 Line state immediately before the HS-0 Line state starting the HS transmission	$40\text{ ns} + 4*UI$	-	$85\text{ ns} + 6*UI$	ns
$T_{HS-SETTLE}$	Time interval during which the HS receiver shall ignore any Data Lane HS transitions, starting from the beginning of $T_{HS-PREPARE}$ . The HS receiver shall ignore any Data Lane transitions before the minimum value, and the HS receiver shall respond to any Data Lane transitions after the maximum value.	$85\text{ ns} + 6*UI$	-	$145\text{ ns} + 10*UI$	ns
$T_{HS-TRAIL}$	Time that the transmitter drives the flipped differential state after last payload data bit of a HS transmission burst.	$\max(n*8*UI, 60\text{ ns} + n*4*UI)^{(10)}$	-	-	ns
$T_{LPX}$	Transmitted length of any Low-Power state period	50	-	-	ns
$T_{HS-PREPARE} + T_{HS-ZERO}$	$T_{HS-PREPARE}$ + time that the transmitter drives the HS-0 state prior to transmitting the Sync sequence.	$145\text{ ns} + 10*UI$	-	-	ns

<sup>(10)</sup> Where  $n = 1$  in Forward-direction HS mode and  $n = 4$  for Reverse-direction HS mode.

## DDR DRAM

Some T20 FPGAs have a x16 DDR PHY interface supporting DDR3, DDR3L, LPDDR3, and LPDDR2 as well as a memory controller hard IP block. The DDR PHY supports data rates up to 1066 Mbps per lane. The memory controller provides two 128 bit AXI buses to communicate with the FPGA core.



**Note:** The DDR PHY and controller are hard blocks; you cannot bypass the DDR DRAM memory controller to access the PHY directly for non-DDR memory controller applications.

Table 44: DDR DRAM Performance

DDR DRAM Interface	Voltage (V)	Maximum Data Rate (Mbps) per Lane
DDR3	1.5	1066
DDR3L	1.35	1066
LPDDR3	1.2	1066
LPDDR2	1.2	1066

Figure 25: DDR DRAM Block Diagram

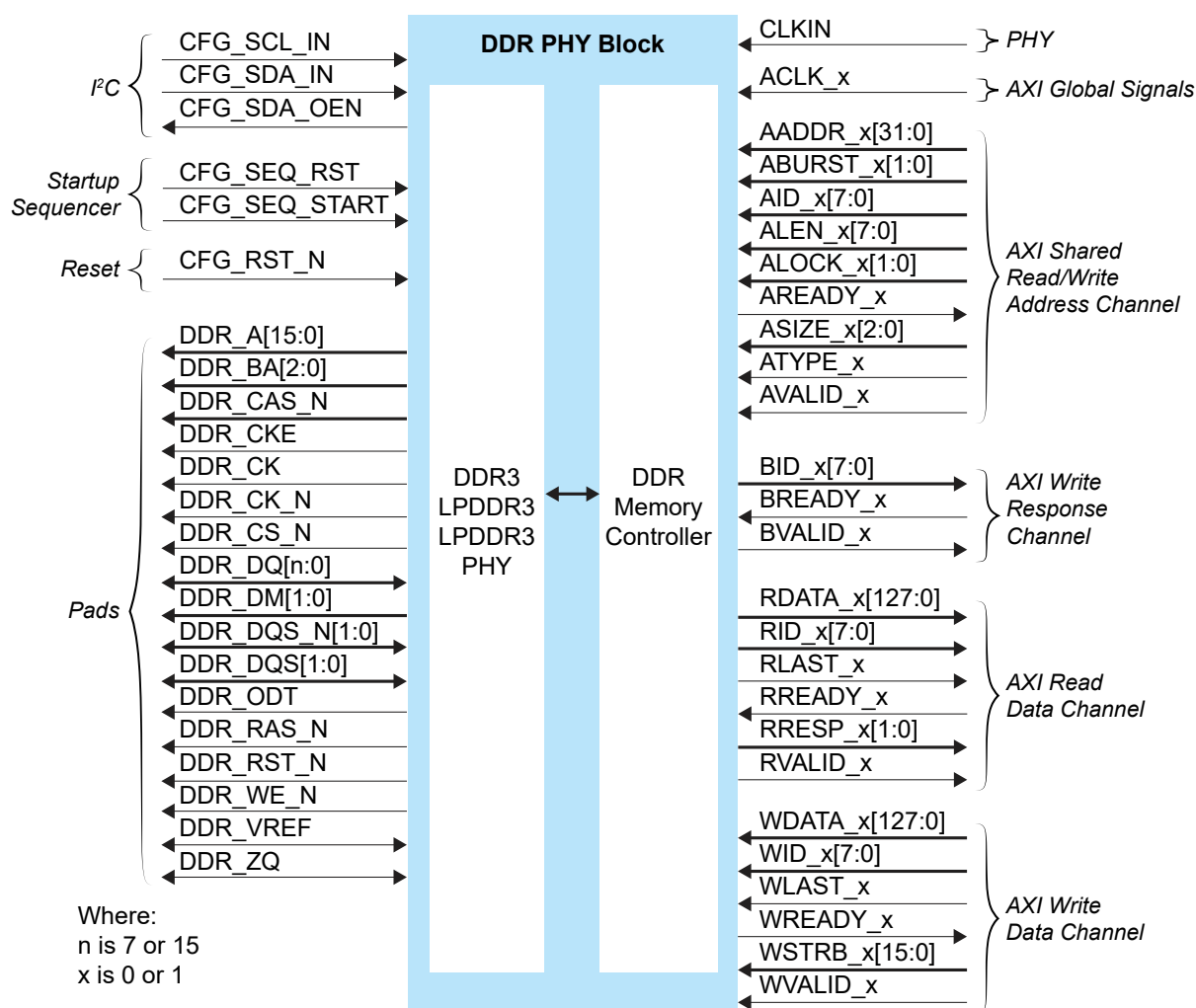

The DDR DRAM block supports an I<sup>2</sup>C calibration bus that can read/write the DDR configuration registers. You can use this bus to fine tune the DDR PHY for high performance.

Figure 26: DDR DRAM Interface Block Diagram

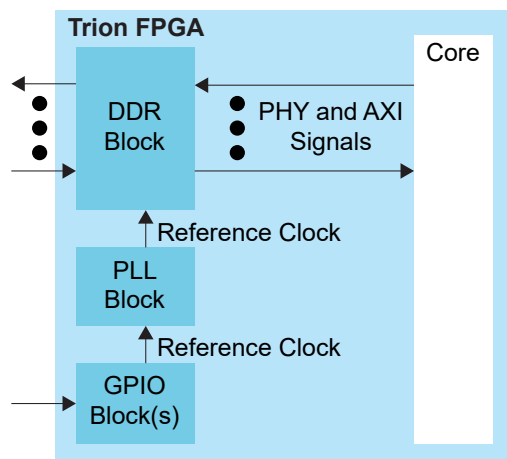

Table 45: PHY Signals (Interface to FPGA Fabric)

Signal	Direction	Clock Domain	Description
CLKIN	Input	N/A	High-speed clock to drive the DDR PHY. A PLL must generate this clock. The clock runs at half of the PHY data rate (for example, 800 Mbps requires a 400 MHz clock). The DDR DRAM block uses the PLL_BR0 CLKOUT0 resource as the PHY clock.

The PLL reference clock must be driven by I/O pads. The Efinix<sup>®</sup> software issues a warning if you do not connect the reference clock to an I/O pad. (Using the clock tree may induce additional jitter and degrade the DDR performance.) Refer to **PLL** on page 19 for more information about the PLL block.



**Important:** Efinix strongly recommends that you do not use any LVDS pins (either single-ended I/O or differential pair) as the primary clock to drive the PLL\_BR0 or the DDR interface will not be initialized during the configuration phase. Make sure to incorporate a user reset and instantiate the DDR Hard Memory Controller-Reset IP to initialize the DDR interface in user mode. Contact Efinix support if you need LVDS pins as the primary clock for the PLL\_BR0 DDR interface

Table 46: AXI Global Signals (Interface to FPGA Fabric)

Signal	Direction	Clock Domain	Description
ACLK_0, ACLK_1	Input	N/A	AXI clock inputs.

**Table 47: AXI Shared Read/Write Signals (Interface to FPGA Fabric)**

Signal x is 0 or 1	Direction	Clock Domain	Description
AADDR_x[31:0]	Input	ACLK_x	Address. ATYPE defines whether it is a read or write address. It gives the address of the first transfer in a burst transaction.
ABURST_x[1:0]	Input	ACLK_x	Burst type. The burst type and the size determine how the address for each transfer within the burst is calculated.
AID_x[7:0]	Input	ACLK_x	Address ID. This signal identifies the group of address signals. Depends on ATYPE, the ID can be for a read or write address group.
ALEN_x[7:0]	Input	ACLK_x	Burst length. This signal indicates the number of transfers in a burst.
ALOCK_x[1:0]	Input	ACLK_x	Lock type. This signal provides additional information about the atomic characteristics of the transfer.
AREADY_x	Output	ACLK_x	Address ready. This signal indicates that the slave is ready to accept an address and associated control signals.
ASIZE_x[2:0]	Input	ACLK_x	Burst size. This signal indicates the size of each transfer in the burst.
ATYPE_x	Input	ACLK_x	This signal distinguishes whether it is a read or write operation. 0 = read and 1 = write.
AVALID_x	Input	ACLK_x	Address valid. This signal indicates that the channel is signaling valid address and control information.

**Table 48: AXI Write Response Channel Signals (Interface to FPGA Fabric)**

Signal x is 0 or 1	Direction	Clock Domain	Description
BID_x[7:0]	Output	ACLK_x	Response ID tag. This signal is the ID tag of the write response.
BREADY_x	Input	ACLK_x	Response ready. This signal indicates that the master can accept a write response.
BVALID_x	Output	ACLK_x	Write response valid. This signal indicates that the channel is signaling a valid write response.

**Table 49: AXI Read Data Channel Signals (Interface to FPGA Fabric)**

Signal x is 0 or 1	Direction	Clock Domain	Description
RDATA_x[127:0]	Output	ACLK_x	Read data.
RID_x[7:0]	Output	ACLK_x	Read ID tag. This signal is the identification tag for the read data group of signals generated by the slave.
RLAST_x	Output	ACLK_x	Read last. This signal indicates the last transfer in a read burst.
RREADY_x	Input	ACLK_x	Read ready. This signal indicates that the master can accept the read data and response information.
RRESP_x[1:0]	Output	ACLK_x	Read response. This signal indicates the status of the read transfer.
RVALID_x	Output	ACLK_x	Read valid. This signal indicates that the channel is signaling the required read data.

**Table 50: AXI Write Data Channel Signals (Interface to FPGA Fabric)**

Signal x is 0 or 1	Direction	Clock Domain	Description
WDATA_x[127:0]	Input	ACLK_x	Write data.
WID_x[7:0]	Input	ACLK_x	Write ID tag. This signal is the ID tag of the write data transfer.
WLAST_x	Input	ACLK_x	Write last. This signal indicates the last transfer in a write burst.
WREADY_x	Output	ACLK_x	Write ready. This signal indicates that the slave can accept the write data.
WSTRB_x[15:0]	Input	ACLK_x	Write strobes. This signal indicates which byte lanes hold valid data. There is one write strobe bit for each eight bits of the write data bus.
WVALID_x	Input	ACLK_x	Write valid. This signal indicates that valid write data and strobes are available.

**Table 51: DDR DRAM I<sup>2</sup>C Interface Signals**

Signal	Direction	Description
CFG_SCL_IN	Input	Clock input.
CFG_SDA_IN	Input	Data input.
CFG_SDA_OEN	Output	SDA output enable.

**Table 52: DDR DRAM Startup Sequencer Signals**

Signal	Direction	Description
CFG_SEQ_RST	Input	Active-high DDR configuration controller reset.
CFG_SEQ_START	Input	Start the DDR configuration controller.

**Table 53: DDR DRAM Reset Signal**

Signal	Direction	Description
CFG_RST_N	Input	Active-low master DDR DRAM reset. After you de-assert RST_N, you need to reconfigure and initialize before performing memory operations.

Table 54: DDR DRAM Pads

Signal	Direction	Description
DDR_A[15:0]	Output	Address signals to the memories.
DDR_BA[2:0]	Output	Bank signals to/from the memories.
DDR_CAS_N	Output	Active-low column address strobe signal to the memories.
DDR_CKE	Output	Active-high clock enable signals to the memories.
DDR_CK	Output	Active-high clock signals to/from the memories. The clock to the memories and to the memory controller must be the same clock frequency and phase.
DDR_CK_N	Output	Active-low clock signals to/from the memories. The clock to the memories and to the memory controller must be the same clock frequency and phase.
DDR_CS_N	Output	Active-low chip select signals to the memories.
DDR_DQ[n:0]	Bidirectional	Data bus to/from the memories. For writes, the pad drives these signals. For reads, the memory drives these signals. These signals are connected to the DQ inputs on the memories. $n$ is 7 or 15 depending on the DQ Width Configuration setting.
DDR_DM[n]	Output	Active-high data-mask signals to the memories. $n$ is 0 or 1:0 depending on the DQ width.
DDR_DQS_N[n:0]	Bidirectional	Differential data strobes to/from the memories. For writes, the pad drives these signals. For reads, the memory drives these signals. These signals are connected to the DQS inputs on the memories. $n$ is 0 or 1:0 depending on the DQ width.
DDR_DQS[n:0]	Bidirectional	
DDR_ODT	Output	ODT signal to the memories.
DDR_RAS_N	Output	Active-low row address strobe signal to the memories.
DDR_RST_N	Output	Active-low reset signals to the memories.
DDR_WE_N	Output	Active-low write enable strobe signal to the memories.
DDR_VREF	Bidirectional	Reference voltage.
DDR_ZQ	Bidirectional	ZQ calibration pin.

## DDR Interface Designer Settings

The following tables describe the settings for the DDR block in the Interface Designer.

Table 55: Base Tab

Parameter	Choices	Notes
DDR Resource	None, DDR_0	Only one resource available.
Instance Name	User defined	Indicate the DDR instance name. This name is the prefix for all DDR signals.
Memory Type	DDR3, LPDDR2, LPDDR3	Choose the memory type you want to use.

Table 56: Configuration Tab

Parameter	Choices	Notes
Select Preset		The <b>Select Preset</b> button opens a list of popular DDR memory configurations. Choose a preset to populate the configuration choices. If you do not want to use a preset, you can specify the memory configuration manually.
DQ Width	x8, x16	DQ bus width.
Type	DDR3, LPDDR2, LPDDR3	Memory type.
Enable Advanced Density Setting	On, Off	If you do not want to use the available density from the <b>Density</b> parameter, you can set the memory row and column width.
Row Width	0 - 99	Specify the memory row width.
Column Width	0 - 99	Specify the memory column width.
<b>DDR3</b>		
Speed Grade	1066E, 1066F, 1066G, 800D, 800E	Memory speed.
Width	x8, x16	Memory width.
Density	1G, 2G, 4G, 8G	Memory density in bits.
<b>LPDDR2</b>		
Speed Grade	400, 533, 667, 800, 1066	Memory speed.
Width	x16	Memory width.
Density	256M, 512M, 1G, 2G, 4G	Memory density in bits.
<b>LPDDR3</b>		
Speed Grade	800, 1066	Memory speed.
Width	x16	Memory width.
Density	4G, 8G	Memory density in bits.

Table 57: Advanced Options Tab - FPGA Setting Subtab

Parameter	Choices	Notes
FPGA Input Termination	Varies depending on the memory type	Specify the termination value for the FPGA input/output pins.
FPGA Output Termination		

Table 58: Advanced Options Tab - Memory Mode Register Settings Subtab

Parameter	Choices	Notes
<b>DDR3</b>		
Burst Length	8	Specify the burst length (only 8 is supported).
DLL Precharge Power Down	On, Off	Specify whether the DLL in the memory device is off or on during precharge power-down.
Memory Auto Self-Refresh	Auto, Manual	Turn on or off auto-self refresh feature in memory device.
Memory CAS Latency (CL)	5 - 14	Specify the number of clock cycle between read command and the availability of output data at the memory device.
Memory Write CAS Latency (CWL)	5 - 12	Specify the number of clock cycle from the releasing of the internal write to the latching of the first data in at the memory device.
Memory Dynamic ODT (Rtt_WR)	Off, RZQ/2, RZQ/4	Specify the mode of dynamic ODT feature of memory device.
Memory Input Termination (Rtt_nom)	Off, RZQ/2, RZQ/4, RZQ/6, RZQ/8, RZQ/12	Specify the input termination value of the memory device.
Memory Output Termination	RZQ/6, RZQ/7	Specify the output termination value of the memory device.
Read Burst Type	Interleaved, Sequential	Specify whether accesses within a give burst are in sequential or interleaved order.
Self-Refresh Temperature	Extended, Normal	Specify whether the self refresh temperature is normal or extended mode.
<b>LPDDR2</b>		
FPGA Input Termination ( $\Omega$ )	120, Off	Specify the input termination of the FPGA device. Used in non-JEDEC standard only.   <b>Note:</b> Enabling this option leads to higher power consumption.
Burst Length	8	Specify the burst length (only 8 is supported).
Output Drive Strength	34.3, 40, 48, 60, 80, 120	Specify the output termination value of memory device.
Read Burst Type	Interleaved, Sequential	Specify whether accesses within a given burst are in sequential or interleaved order.
Read/Write Latency	RL=3/WL=1, RL=4/WL=2 RL=5/WL=2, RL=6/WL=3 RL=7/WL=4, RL=8/WL=4	Specify the read/write latency of the memory device.
<b>LPDDR3</b>		
DQ ODT	Disable, RZQ1, RZQ2, RZQ4	Specify the input termination value of memory device.
Output Drive Strength	34.3 34.3 pull-down/40 pull up 34.3 pull-down/48 pull up 40 40 pull down/48 pull up 48	Specify the output termination value of memory device.

Parameter	Choices	Notes
Read/Write Latency	RL=3/WL=1, RL=6/WL=3 RL=8/WL=4, RL=9/WL=5	Specify the read/write latency of the memory device.

**Table 59: Advanced Options Tab - Memory Timing Settings Subtab**

Parameter	Choices	Notes
tFAW, Four Bank Active Window (ns)	User defined	Enter the timing parameters from the memory device's data sheet.
tRAS, Active to Precharge Command Period (ns)		
tRC, Active to Active or REF Command Period (ns)		
tRCD, Active to Read or Write Delay (ns)		
tREFI, Average Periodic Refresh Interval (ns)		
tRFC, Refresh to Active or Refresh to Refresh Delay (ns)		
tRP, Precharge Command Period (ns)		
tRRD, Active to Active Command Period (ns)		
tRTP, Internal Read to Precharge Delay (ns)		
tWTR, Internal Write to Read Command Delay (ns)		

**Table 60: Advanced Options Tab - Controller Settings Subtab**

Parameter	Choices	Notes
Controller to Memory Address Mapping	BANK-ROW-COL ROW-BANK-COL ROW-COL_HIGH-BANK-COL_LOW	Specify the mapping between the address of AXI interface and column, row, and bank address of memory device.
Enable Auto Power Down	Active, Off, Pre-Charge	Specify whether to allow automatic entry into power-down mode (pre-charge or active) after a specific amount of idle time.
Enable Self Refresh Controls	No, Yes	Specify whether to enable automatic entry into self-refresh mode after specific amount of idle period.

**Table 61: Advanced Options Tab - Gate Delay Tuning Settings Subtab**

Parameter	Choices	Notes
Enable Gate Delay Override	On or off	Turning this option on allows you to fine-tune the gate-delay values. This is an expert only setting.
Gate Coarse Delay Tuning	0 - 5	
Gate Fine Delay Tuning	0 - 255	

**Table 62: Control Tab**

Option	Notes
Disable Control	When selected, this option disables calibration and user reset.
Enable Calibration	Turn on to enable optional PHY calibration pins (master reset, SCL, and SDA pins). Efinix recommends that you use the default pin names. The names are prefixed with the instance name you specified in the Base tab. These pins connect to the DDR Hard Memory Controller - Calibration and Reset IP core.
Enable User Reset	Turn on to enable optional reset pins (master reset and sequencer start/reset). Efinix recommends that you use the default pin names. The names are prefixed with the instance name you specified in the Base tab. These pins connect to the DDR Hard Memnory Controller - Reset IP core.
Enable Reset and Calibration	Turn on to enable the pins for calibration and user reset. These pins connect to the DDR Hard Memory Controller - Calibration and Reset IP core.

**Table 63: AXI 0 and AXI 1 Tabs**

Parameter	Choices	Notes
Enable Target 0	On or off	Turn on to enable the AXI 0 interface.
Enable Target 1		Turn on to enable the AXI 1 interface.
AXI Clock Input Pin name	User defined	Specify the name of the AXI input clock pin.
Invert AXI Clock Input	On or off	Turn on to invert the AXI clock.
Shared Read/Write Address Channel tab Write Response Channel tab Read Data Channel tab Write Data Channel tab	User defined	This tab defines the AXI signal names. Efinix recommends that you use the default names. The signals are prefixed with the instance name you specified in the Base tab.

## SPI Flash Memory

The QFP100F3 packages include a T20 FPGA and a SPI flash memory. The SPI flash memory has a density of 16 Mbits and a clock rate of up to 20 MHz. In active configuration mode, the FPGA is configured using the configuration bitstream in the SPI flash memory. Typically you can fit two compressed bitstream images into the QFP100F3 SPI flash. The SPI flash memory's VCC is powered by VCCIO1A\_1B\_1C.

In SPI active configuration mode, the FPGA is configured using a bitstream stored in the SPI flash device. During configuration, the maximum clock frequency for the flash device is specified in **SPI Active** on page 75. When the FPGA is in user mode, you can access the flash at the flash device's maximum clock frequency (although different SPI flash commands may have different maximum clock frequencies).

When a configuration bitstream is stored in the SPI flash and the SPI active hardware connection is properly established, the SPI active configuration can automatically start after the power-up. In QFP100F3 packages you are only required to connect the SS\_N pin to the SPI\_CS\_N pin for the SPI active configuration to start automatically. This is additional to other required configuration pin settings depending on the configuration mode you select.



**Learn more:** Refer to the [AN 006: Configuring Trion FPGAs](#) for detailed configuration requirements.

You can also use the SPI flash to store user data during user mode. To read or write the SPI flash during user mode, you must create the SPI flash interface block in the Efinity Interface Designer.



**Learn more:** Refer to [Trion Interfaces User Guide](#) for more information about using the SPI flash interface block in the Efinity Interface Designer.



**Important:** You can only use the internal SPI flash in user mode if no LVDS TX is used.

*Figure 27: Connections between FPGA and SPI Flash Device inside the Package*

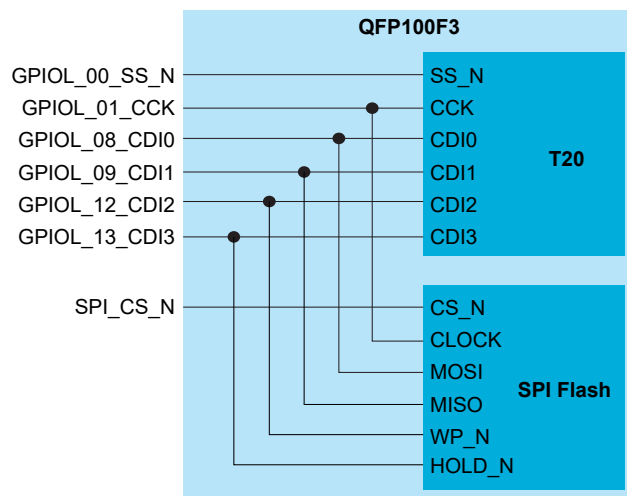

**Table 64: SPI Flash Memory Signals (Interface to FPGA Fabric)**

<b>Signal</b>	<b>Direction</b>	<b>Description</b>
SCLK	Input	Clock output to SPI flash memory.
MOSI	Input	Data output to SPI flash memory.
MISO	Output	Data input from SPI flash memory.
WP_N	Input	Active-low write protect signal.
HOLD_N	Input	Active-low hold signal.
SPI_CS_N	Input	Active-low SPI flash memory chip select.

# Power Up Sequence

Efnix® recommends the following power up sequence when powering Trion® FPGAs:

Figure 28: Trion® FPGAs Power Up Sequence

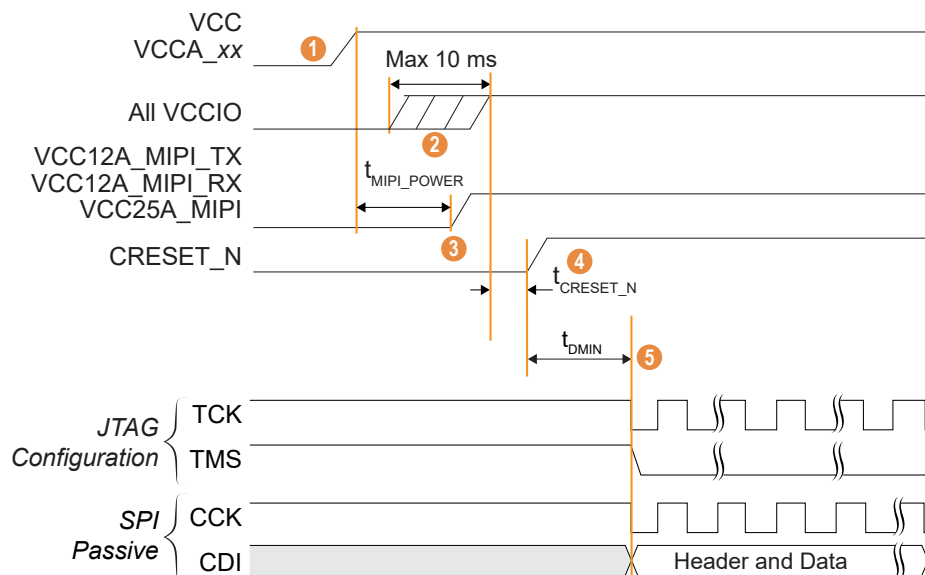

1. Power up VCC and VCCA\_xx first.
2. When VCC and VCCA\_xx are stable, power up all VCCIO pins. There is no specific timing delay between the VCCIO pins.
3. Apply power to VCC12A\_MIPI\_TX, VCC12A\_MIPI\_RX, and VCC25A\_MIPI at least  $t_{MIPI\_POWER}$  after VCC is stable.



**Important:** Ensure the power ramp rate is within VCCIO/10 V/ms to 10 V/ms.

4. After all power supplies are stable, hold CRESET\_N low for a duration of  $t_{CRESET\_N}$  before asserting CRESET\_N from low to high to trigger active SPI programming (the FPGA loads the configuration data from an external flash device).
5. FPGA configuration can begin after there has been a  $t_{DMIN}$  minimum delay after CRESET\_N goes high (see **SPI Passive** and **JTAG** for the delay specification).

When you are not using the GPIO, MIPI, DDR or PLL resources, connect the pins as shown in the following table.



**Note:** Refer to **Configuration Timing** on page 74 and **MIPI Power-Up Timing** on page 71 for timing information.

## Power Supply Current Transient

You may observe an inrush current on the dedicated power rail during power-up. You must ensure that the power supplies selected in your board meets the current requirement during power-up and the estimated current during user mode. Use the Power Estimator to calculate the estimated current during user mode.

*Table 65: Maximum Power Supply Current Transient*

Power Supply	Package	Maximum Power Supply Current Transient <sup>(11)(12)</sup>	Unit
VCC	W80, Q100F3, Q144, F169, F256	35	mA
	F324, F400	57	mA

## Unused Resources and Features

*Table 66: Connection Requirements for Unused Resources*

Unused Resource	Pin	Note
GPIO Bank	VCCIOxx	Connect to either 1.8 V, 2.5 V, or 3.3 V.
PLL	VCCA_PLL	Connect to VCC.
MIPI	VCC12A_MIPI_TX	Connect to VCC (1.2 V).
	VCC12A_MIPI_RX	Connect to VCC (1.2 V).
	VCC25A_MIPI	Connect to VCC (1.2 V).
DDR	VCCIO_DDR	Floating. Leave unconnected.
	DDR_VREF	Connect to ground.

<sup>(11)</sup> Inrush current for other power rails are not significant in Trion® FPGAs.

<sup>(12)</sup> Measured at room temperature.

# Configuration

The T20 FPGA contains volatile Configuration RAM (CRAM). The user must configure the CRAM for the desired logic function upon power-up and before the FPGA enters normal operation. The FPGA's control block manages the configuration process and uses a bitstream to program the CRAM. The Efinity<sup>®</sup> software generates the bitstream, which is design dependent. You can configure the T20 FPGA(s) in SPI active, SPI passive, or JTAG mode.



**Learn more:** Refer to [AN 006: Configuring Trion FPGAs](#) for details on the dedicated configuration pins and how to configure FPGA(s).

Figure 29: High-Level Configuration Options

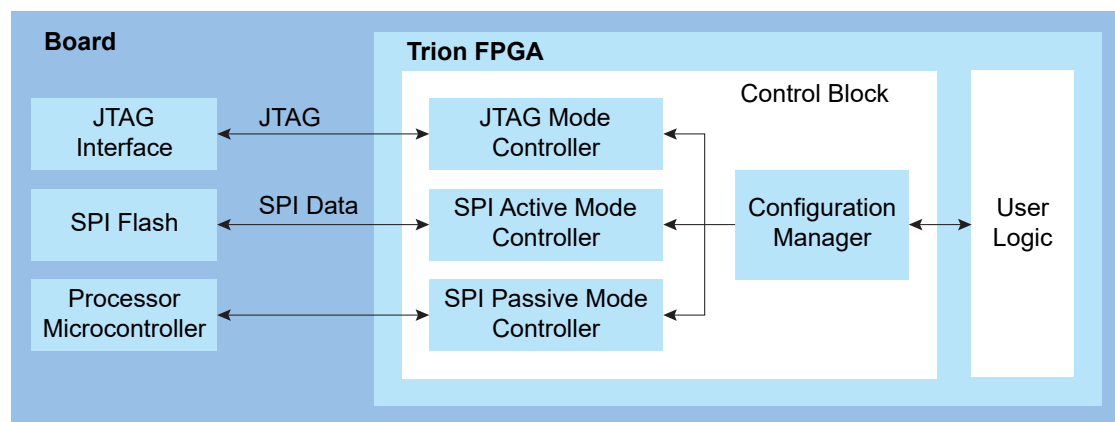

In active mode, the FPGA controls the configuration process. An oscillator circuit within the FPGA provides the configuration clock. The bitstream is typically stored in an external serial flash device, which provides the bitstream when the FPGA requests it.

The control block sends out the instruction and address to read the configuration data. First, it issues a release from power-down instruction to wake up the external SPI flash. Then, it waits for at least 30  $\mu$ s before issuing a fast read command to read the content of SPI flash from address 24h'000000.

In passive mode, the FPGA is the slave and relies on an external master to provide the control, bitstream, and clock for configuration. Typically the master is a microcontroller or another FPGA in active mode.

In JTAG mode, you configure the FPGA via the JTAG interface.

## Supported Configuration Modes

Table 67: T20 Configuration Modes by Package

Configuration Mode	Width	WLCSP80, F169	Q100F3, Q144	F256	F324, F400
Active	x1	✓	✓	✓	✓ <sup>(13)</sup>
	x2	✓	✓	✓	✓
	x4	✓	✓	✓	✓
Passive	x1	✓	✓	✓	✓
	x2	✓	✓	✓	✓
	x4	✓	✓	✓	✓
	x8		✓	✓	✓
	x16		✓	✓	✓
	x32			✓	✓
JTAG	x1	✓	✓	✓	✓



**Learn more:** Refer to [AN 006: Configuring Trion FPGAs](#) for more information.

## Mask-Programmable Memory Option

The T20 FPGA is equipped with one-time programmable MPM. With this feature, you use on-chip MPM instead of an external serial flash device to configure the FPGA. This option is for systems that require an ultra-small factor and the lowest cost structure such that an external serial flash device is undesirable and/or not required at volume production. MPM is a one-time factory programmable option that requires a Non-Recurring Engineering (NRE) payment. To enable MPM, submit your design to our factory; our Applications Engineers (AEs) convert your design into a single configuration mask to be specially fabricated.

<sup>(13)</sup> This package does not support active SPI multi-image configuration in x1 mode. Instead, use x2 or x4, or alternatively, use the internal reconfiguration feature as described in AN 010: Using the Internal Reconfiguration Feature to Remotely Update Trion FPGAs.

# DC and Switching Characteristics (W80, Q100F3, Q144, F169, and F256)



**Note:** Speed grade Q4 is only available in F169 packages. Speed grades C3, C4, and C4L are not available in W80 packages.

**Table 68: Absolute Maximum Ratings**

Conditions beyond those listed may cause permanent damage to the device. Device operation at the absolute maximum ratings for extended periods of time has adverse effects on the device.

Symbol	Description	Min	Max	Units
VCC	Core power supply	-0.5	1.42	V
VCCIO	I/O bank power supply	-0.5	4.6	V
	I/O bank 1A_1B_1C power supply (QFP100F3)	-0.5	4.1	V
VCCA_PLL	PLL analog power supply	-0.5	1.42	V
VCC25A_MIP10 VCC25A_MIP11	2.5 V analog power supply for MIPI	-0.5	2.75	V
VCC12A_MIP10_TX VCC12A_MIP11_TX	1.2 V TX analog power supply for MIPI	-0.5	1.42	V
VCC12A_MIP10_RX VCC12A_MIP11_RX	1.2 V RX analog power supply for MIPI	-0.5	1.42	V
V <sub>IN</sub>	I/O input voltage	-0.5	4.6	V
I <sub>IN</sub>	Maximum current through any pin in a powered or unpowered bank when forward biasing the clamp diode. <sup>(15)</sup>	-	10	mA
T <sub>J</sub>	Operating junction temperature	-40	125	°C
	Operating junction temperature (QFP100F3)	-40	105	°C
T <sub>STG</sub>	Storage temperature, ambient	-55	150	°C

<sup>(14)</sup> Supply voltage specification applied to the voltage taken at the device pins with respect to ground, not at the power supply.

<sup>(15)</sup> Should not exceed a total of 120 mA per bank.

**Table 69: Recommended Operating Conditions (C3, C4, Q4, and I4 Speed Grades)<sup>(14)</sup>**

Symbol	Description	Min	Typ	Max	Units
VCC	Core power supply	1.15	1.2	1.25	V
VCCIO	1.8 V I/O bank power supply	1.71	1.8	1.89	V
	2.5 V I/O bank power supply	2.38	2.5	2.63	V
	3.3 V I/O bank power supply	3.14	3.3	3.47	V
VCCA_PLL	PLL analog power supply	1.15	1.2	1.25	V
VCC25A_MIP10 VCC25A_MIP11	2.5 V analog power supply for MIPI	2.38	2.5	2.63	V
VCC12A_MIP10_TX VCC12A_MIP11_TX	1.2 V TX analog power supply for MIPI	1.15	1.2	1.25	V
VCC12A_MIP10_RX VCC12A_MIP11_RX	1.2 V RX analog power supply for MIPI	1.15	1.2	1.25	V
V <sub>IN</sub>	I/O input voltage <sup>(16)</sup>	-0.3	-	VCCIO + 0.3	V
T <sub>JCOM</sub>	Operating junction temperature, commercial	0	-	85	°C
T <sub>JIND</sub>	Operating junction temperature, industrial	-40	-	100	°C
T <sub>JAUT</sub>	Operating junction temperature, automotive	-40	-	105	°C

**Table 70: Recommended Operating Conditions (C4L and I4L Speed Grades)<sup>(14)</sup>**

Symbol	Description	Min	Typ	Max	Units
VCC	Core power supply	1.05	1.1	1.15	V
VCCIO	1.8 V I/O bank power supply	1.71	1.8	1.89	V
	2.5 V I/O bank power supply	2.38	2.5	2.63	V
	3.3 V I/O bank power supply	3.14	3.3	3.47	V
VCCA_PLL	PLL analog power supply	1.05	1.1	1.15	V
VCC25A_MIP10 VCC25A_MIP11	2.5 V analog power supply for MIPI	2.38	2.5	2.63	V
VCC12A_MIP10_TX VCC12A_MIP11_TX	1.1 V TX analog power supply for MIPI	1.05	1.1	1.15	V
VCC12A_MIP10_RX VCC12A_MIP11_RX	1.1 V RX analog power supply for MIPI	1.05	1.1	1.15	V
V <sub>IN</sub>	I/O input voltage <sup>(17)</sup>	-0.3	-	VCCIO + 0.3	V
T <sub>JCOM</sub>	Operating junction temperature, commercial	0	-	85	°C
T <sub>JIND</sub>	Operating junction temperature, industrial	-40	-	100	°C

<sup>(16)</sup> Values applicable to both input and tri-stated output configuration.<sup>(17)</sup> Values applicable to both input and tri-stated output configuration.

**Table 71: Power Supply Ramp Rates**

Symbol	Description	Min	Max	Units
$t_{RAMP}$	Power supply ramp rate for all supplies.	VCCIO/10	10	V/ms

**Table 72: Single-Ended I/O DC Electrical Characteristics**

I/O Standard	$V_{IL}$ (V)		$V_{IH}$ (V)		$V_{OL}$ (V)	$V_{OH}$ (V)
	Min	Max	Min	Max	Max	Min
3.3 V LVCMOS	-0.3	0.8	2	VCCIO + 0.3	0.2	VCCIO - 0.2
3.3 V LVTTTL	-0.3	0.8	2	VCCIO + 0.3	0.4	2.4
2.5 V LVCMOS	-0.3	0.7	1.7	VCCIO + 0.3	0.5	1.8
1.8 V LVCMOS	-0.3	0.35 * VCCIO	0.65 * VCCIO	VCCIO + 0.3	0.45	VCCIO - 0.45

**Table 73: Single-Ended I/O and Dedicated Configuration Pins Schmitt Trigger Buffer Characteristic**

Voltage (V)	VT+ (V) Schmitt Trigger Low-to-High Threshold	VT- (V) Schmitt Trigger High-to-Low Threshold	Input Leakage Current ( $\mu$ A)	Tri-State Output Leakage Current ( $\mu$ A)
3.3	1.73	1.32	$\pm 10$	$\pm 10$
2.5	1.37	1.01	$\pm 10$	$\pm 10$
1.8	1.05	0.71	$\pm 10$	$\pm 10$

**Table 74: Single-Ended I/O Buffer Drive Strength Characteristics**

Junction temperature at  $T_j = 25^\circ\text{C}$ , power supply at nominal voltage.

CDONE has a drive strength of 1.

I/O Standard	3.3 V		2.5 V		1.8 V	
	$I_{OH}$ (mA)	$I_{OL}$ (mA)	$I_{OH}$ (mA)	$I_{OL}$ (mA)	$I_{OH}$ (mA)	$I_{OL}$ (mA)
1	14.4	8.0	9.1	8.0	5.1	4.4
2	19.1	10.5	12.2	10.5	6.8	5.8
3	23.9	13.3	15.2	13.4	8.6	7.3
4	28.7	15.8	18.2	15.9	10.3	8.6

**Table 75: Single-Ended I/O Internal Weak Pull-Up and Pull-Down Resistance**

CDONE and CRESET\_N also have an internal weak pull-up with these values.

I/O Standard	Internal Pull-Up			Internal Pull-Down			Units
	Min	Typ	Max	Min	Typ	Max	
3.3 V LVTTTL/LVCMOS	27	40	65	30	47	83	$k\Omega$
2.5 V LVCMOS	35	55	120	37	62	118	$k\Omega$
1.8 V LVCMOS	70	90	200	80	99	300	$k\Omega$

**Table 76: LVDS Pins Configured as Single-Ended I/O DC Electrical Characteristics**

I/O Standard	V <sub>IL</sub> (V)		V <sub>IH</sub> (V)		V <sub>OL</sub> (V)	V <sub>OH</sub> (V)
	Min	Max	Min	Max	Max	Min
3.3 V LVCMOS	-0.3	0.8	2	VCCIO + 0.3	0.2	VCCIO - 0.2
3.3 V LVTTTL	-0.3	0.8	2	VCCIO + 0.3	0.4	2.4

**Table 77: LVDS Pins Configured as Single-Ended I/O Buffer Drive Strength Characteristics**

Junction temperature at T<sub>J</sub> = 25 °C, power supply at nominal voltage, device in nominal process (TT).

I/O Standard	Drive Strength	
	I <sub>OH</sub> (mA)	I <sub>OL</sub> (mA)
3.3 V	37.6	22

**Table 78: LVDS Pins Configured as Single-Ended I/O DC Electrical Characteristics**

Voltage (V)	Input Leakage Current (μA)	Tri-State Output Leakage Current (μA)
3.3	±10	±10

**Table 79: LVDS Pins Configured as Single-Ended I/O Internal Weak Pull-Up Resistance**

I/O Standard	Internal Pull-Up			Units
	Min	Typ	Max	
3.3 V LVTTTL/LVCMOS	27	40	65	kΩ

**Table 80: Maximum Toggle Rate**

Efinix recommends that you perform simulations using the IBIS model to determine the maximum toggle rate for your design.

I/O Standard	Package	Max Toggle Rate	Units
3.3 V LVTTTL/LVCMOS	All	400	Mbps
2.5 V LVCMOS	All	400	Mbps
1.8 V LVCMOS	All	400	Mbps
LVDS	All others	800	Mbps
	QFP100F3, QFP144	600	Mbps

**Table 81: Single-Ended I/O and LVDS Pins Configured as Single-Ended I/O Rise and Fall Time**

Data are based on the following IBIS simulation setup:

- Weakest drive strength model
- Typical simulation corner setting
- RLC circuit with 6.6 pF capacitance, 16.6 nH inductance, 0.095 ohm resistance, and 25 °C temperature



**Note:** For a more accurate data, you need to perform the simulation with your own circuit.

I/O Standard	Rise Time ( $T_R$ )		Fall Time ( $T_F$ )		Units
	Slow Slew Rate Enabled	Slow Slew Rate Disabled	Slow Slew Rate Enabled	Slow Slew Rate Disabled	
3.3 V LVTTTL/LVCMOS	1.13	1.02	1.24	1.17	ns
2.5 V LVCMOS	1.4	1.3	1.44	1.31	ns
1.8 V LVCMOS	2.14	2.01	2.05	1.85	ns
LVDS pins configured as 3.3 V LVTTTL/LVCMOS	0.45		0.44		ns

**Table 82: Block RAM Characteristics**

Symbol	Description	Speed Grade		Units
		C3, C4L, I4L	C4, I4, Q4	
$f_{MAX}$	Block RAM maximum frequency.	310	400	MHz

**Table 83: Multiplier Block Characteristics**

Symbol	Description	Speed Grade		Units
		C3, C4L, I4L	C4, I4, Q4	
$f_{MAX}$	Multiplier block maximum frequency.	310	400	MHz

# DC and Switching Characteristics (F324 and F400)

**Table 84: Absolute Maximum Ratings**

Conditions beyond those listed may cause permanent damage to the device. Device operation at the absolute maximum ratings for extended periods of time has adverse effects on the device.

Symbol	Description	Min	Max	Units
VCC	Core power supply	-0.5	1.42	V
VCCIO	I/O bank power supply	-0.5	4.6	V
VCCA_PLL	PLL analog power supply	-0.5	1.42	V
VCCIO_DDR	DDR power supply	-0.5	1.65	V
VCC25A_MIP10 VCC25A_MIP11	2.5 V analog power supply for MIPI	-0.5	2.75	V
VCC12A_MIP10_TX VCC12A_MIP11_TX	1.2 V TX analog power supply for MIPI	-0.5	1.42	V
VCC12A_MIP10_RX VCC12A_MIP11_RX	1.2 V RX analog power supply for MIPI	-0.5	1.42	V
V <sub>IN</sub>	I/O input voltage	-0.5	4.6	V
I <sub>IN</sub>	Maximum current through any pin in a powered or unpowered bank when forward biasing the clamp diode. <sup>(19)</sup>	-	10	mA
T <sub>J</sub>	Operating junction temperature	-40	125	°C
T <sub>STG</sub>	Storage temperature, ambient	-55	150	°C

<sup>(18)</sup> Supply voltage specification applied to the voltage taken at the device pins with respect to ground, not at the power supply.

<sup>(19)</sup> Should not exceed a total of 120 mA per bank.

Table 85: Recommended Operating Conditions (C3, C4, and I4 Speed Grades)<sup>(18)</sup>

Symbol	Description	Min	Typ	Max	Units
VCC	Core power supply	1.15	1.2	1.25	V
VCCIO	1.8 V I/O bank power supply	1.71	1.8	1.89	V
	2.5 V I/O bank power supply	2.38	2.5	2.63	V
	3.3 V I/O bank power supply	3.14	3.3	3.47	V
VCCIO_DDR	DDR3	1.425	1.5	1.575	V
	DDR3L	1.283	1.35	1.45	V
	LPDDR3	1.14	1.2	1.3	V
	LPDDR2	1.14	1.2	1.3	V
VCCA_PLL	PLL analog power supply	1.15	1.2	1.25	V
VCC25A_MIP10 VCC25A_MIP11	2.5 V analog power supply for MIPI	2.38	2.5	2.63	V
VCC12A_MIP10_TX VCC12A_MIP11_TX	1.2 V TX analog power supply for MIPI	1.15	1.2	1.25	V
VCC12A_MIP10_RX VCC12A_MIP11_RX	1.2 V RX analog power supply for MIPI	1.15	1.2	1.25	V
V <sub>IN</sub>	I/O input voltage <sup>(20)</sup>	-0.3	-	VCCIO + 0.3	V
T <sub>JCOM</sub>	Operating junction temperature, commercial	0	-	85	°C
T <sub>JIND</sub>	Operating junction temperature, industrial	-40	-	100	°C

<sup>(20)</sup> Values applicable to both input and tri-stated output configuration.

**Table 86: Recommended Operating Conditions (C4L and I4L Speed Grades)<sup>(18)</sup>**

Symbol	Description	Min	Typ	Max	Units
VCC	Core power supply	1.05	1.1	1.15	V
VCCIO	1.8 V I/O bank power supply	1.71	1.8	1.89	V
	2.5 V I/O bank power supply	2.38	2.5	2.63	V
	3.3 V I/O bank power supply	3.14	3.3	3.47	V
VCCIO_DDR	DDR3	1.425	1.5	1.575	V
	DDR3L	1.283	1.35	1.45	V
	LPDDR3	1.14	1.2	1.3	V
	LPDDR2	1.14	1.2	1.3	V
VCCA_PLL	PLL analog power supply	1.05	1.1	1.15	V
VCC25A_MIP10 VCC25A_MIP11	2.5 V analog power supply for MIPI	2.38	2.5	2.63	V
VCC12A_MIP10_TX VCC12A_MIP11_TX	1.2 V TX analog power supply for MIPI	1.05	1.1	1.15	V
VCC12A_MIP10_RX VCC12A_MIP11_RX	1.2 V RX analog power supply for MIPI	1.05	1.1	1.15	V
V <sub>IN</sub>	I/O input voltage <sup>(21)</sup>	-0.3	-	VCCIO + 0.3	V
T <sub>JCOM</sub>	Operating junction temperature, commercial	0	-	85	°C
T <sub>JIND</sub>	Operating junction temperature, industrial	-40	-	100	°C

**Table 87: Power Supply Ramp Rates**

Symbol	Description	Min	Max	Units
t <sub>RAMP</sub>	Power supply ramp rate for all supplies.	VCCIO/10	10	V/ms

<sup>(21)</sup> Values applicable to both input and tri-stated output configuration.

**Table 88: Single-Ended I/O DC Electrical Characteristics**

I/O Standard	V <sub>IL</sub> (V)		V <sub>IH</sub> (V)		V <sub>OL</sub> (V)	V <sub>OH</sub> (V)
	Min	Max	Min	Max	Max	Min
3.3 V LVCMOS	-0.3	0.8	2	VCCIO + 0.3	0.2	VCCIO - 0.2
3.3 V LVTTTL	-0.3	0.8	2	VCCIO + 0.3	0.4	2.4
2.5 V LVCMOS	-0.3	0.7	1.7	VCCIO + 0.3	0.5	1.8
1.8 V LVCMOS	-0.3	0.35 * VCCIO	0.65 * VCCIO	VCCIO + 0.3	0.45	VCCIO - 0.45

**Table 89: Single-Ended I/O and Dedicated Configuration Pins Schmitt Trigger Buffer Characteristic**

Voltage (V)	V <sub>T+</sub> (V) Schmitt Trigger Low-to-High Threshold	V <sub>T-</sub> (V) Schmitt Trigger High-to-Low Threshold	Input Leakage Current (μA)	Tri-State Output Leakage Current (μA)
3.3	1.73	1.32	±10	±10
2.5	1.37	1.01	±10	±10
1.8	1.05	0.71	±10	±10

**Table 90: Single-Ended I/O Buffer Drive Strength Characteristics**

Junction temperature at T<sub>J</sub> = 25 °C, power supply at nominal voltage.

CDONE has a drive strength of 1.

I/O Standard	3.3 V		2.5 V		1.8 V	
	I <sub>OH</sub> (mA)	I <sub>OL</sub> (mA)	I <sub>OH</sub> (mA)	I <sub>OL</sub> (mA)	I <sub>OH</sub> (mA)	I <sub>OL</sub> (mA)
1	14.4	8.0	9.1	8.0	5.1	4.4
2	19.1	10.5	12.2	10.5	6.8	5.8
3	23.9	13.3	15.2	13.4	8.6	7.3
4	28.7	15.8	18.2	15.9	10.3	8.6

**Table 91: Single-Ended I/O Internal Weak Pull-Up and Pull-Down Resistance**

CDONE and CRESET\_N also have an internal weak pull-up with these values.

I/O Standard	Internal Pull-Up			Internal Pull-Down			Units
	Min	Typ	Max	Min	Typ	Max	
3.3 V LVTTTL/LVCMOS	27	40	65	30	47	83	kΩ
2.5 V LVCMOS	35	55	120	37	62	118	kΩ
1.8 V LVCMOS	70	90	200	80	99	300	kΩ

**Table 92: LVDS Pins Configured as Single-Ended I/O DC Electrical Characteristics**

I/O Standard	V <sub>IL</sub> (V)		V <sub>IH</sub> (V)		V <sub>OL</sub> (V)	V <sub>OH</sub> (V)
	Min	Max	Min	Max	Max	Min
3.3 V LVCMOS	-0.3	0.8	2	VCCIO + 0.3	0.2	VCCIO - 0.2
3.3 V LVTTTL	-0.3	0.8	2	VCCIO + 0.3	0.4	2.4
2.5 V LVCMOS	-0.3	0.7	1.7	VCCIO + 0.3	0.5	1.8
1.8 V LVCMOS	-0.3	0.35 * VCCIO	0.65 * VCCIO	VCCIO + 0.3	0.45	VCCIO - 0.45

**Table 93: LVDS Pins Configured as Single-Ended I/O DC Electrical Characteristics**

Voltage (V)	Input Leakage Current (μA)	Tri-State Output Leakage Current (μA)
3.3	±10	±10

**Table 94: LVDS Pins Configured as Single-Ended I/O Buffer Drive Strength Characteristics**

Junction temperature at T<sub>J</sub> = 25 °C, power supply at nominal voltage.

I/O Standard	3.3 V		2.5 V		1.8 V	
	I <sub>OH</sub> (mA)	I <sub>OL</sub> (mA)	I <sub>OH</sub> (mA)	I <sub>OL</sub> (mA)	I <sub>OH</sub> (mA)	I <sub>OL</sub> (mA)
1	14.4	8.0	9.1	8.0	5.1	4.4
2	19.1	10.5	12.2	10.5	6.8	5.8
3	23.9	13.3	15.2	13.4	8.6	7.3
4	28.7	15.8	18.2	15.9	10.3	8.6

**Table 95: LVDS Pins Configured as Single-Ended I/O Internal Weak Pull-Up Resistance**

I/O Standard	Internal Pull-Up			Units
	Min	Typ	Max	
3.3 V LVTTTL/LVCMOS	27	40	65	kΩ
2.5 V LVCMOS	35	55	95	kΩ
1.8 V LVCMOS	53	90	167	kΩ

**Table 96: Single-Ended I/O and LVDS Pins Configured as Single-Ended I/O Rise and Fall Time**

Data are based on the following IBIS simulation setup:

- Weakest drive strength model
- Typical simulation corner setting
- RLC circuit with 6.6 pF capacitance, 16.6 nH inductance, 0.095 ohm resistance, and 25 °C temperature



**Note:** For a more accurate data, you need to perform the simulation with your own circuit.

I/O Standard	Rise Time ( $T_R$ )		Fall Time ( $T_F$ )		Units
	Slow Slew Rate Enabled	Slow Slew Rate Disabled	Slow Slew Rate Enabled	Slow Slew Rate Disabled	
3.3 V LVTTTL/LVCMOS	1.13	1.02	1.24	1.17	ns
2.5 V LVCMOS	1.4	1.3	1.44	1.31	ns
1.8 V LVCMOS	2.14	2.01	2.05	1.85	ns
LVDS pins configured as 3.3 V LVTTTL/LVCMOS	0.45		0.44		ns

**Table 97: Maximum Toggle Rate**

Efinix recommends that you perform simulations using the IBIS model to determine the maximum toggle rate for your design.

I/O Standard	Max Toggle Rate	Units
3.3 V LVTTTL/LVCMOS	400	Mbps
2.5 V LVCMOS	400	Mbps
1.8 V LVCMOS	400	Mbps
LVDS	800	Mbps

**Table 98: Block RAM Characteristics**

Symbol	Description	Speed Grade		Units
		C3, C4L, I4L	C4, I4	
$f_{MAX}$	Block RAM maximum frequency.	310	400	MHz

**Table 99: Multiplier Block Characteristics**

Symbol	Description	Speed Grade		Units
		C3, C4L, I4L	C4, I4	
$f_{MAX}$	Multiplier block maximum frequency.	310	400	MHz

# LVDS I/O Electrical and Timing Specifications

The LVDS pins comply with the EIA/TIA-644 electrical specifications.



**Note:** The LVDS RX supports the sub-lvds, slvs, HiVcm, RSDS and 3.3 V LVPECL differential I/O standards with a transfer rate of up to 800 Mbps.

**Table 100: LVDS I/O Electrical Specifications**

Parameter	Description	Test Conditions/ Options	Min	Typ	Max	Unit
V <sub>CCIO</sub>	LVDS I/O Supply Voltage	-	2.97	3.3	3.63	V
<b>LVDS TX</b>						
V <sub>OD</sub>	Output Differential Voltage	Reduce VOD Swing option disabled	250	350	450	mV
		Reduce VOD Swing option enabled	150	200	250	mV
Δ V <sub>OD</sub>	Change in V <sub>OD</sub>	-	-	-	50	mV
V <sub>OCM</sub>	Output Common Mode Voltage	RT = 100 Ω	1,125	1,250	1,375	mV
Δ V <sub>OCM</sub>	Change in V <sub>OCM</sub>	-	-	-	50	mV
V <sub>OH</sub>	Output High Voltage	RT = 100 Ω	-	-	1475	mV
V <sub>OL</sub>	Output Low Voltage	RT = 100 Ω	925	-	-	mV
I <sub>SAB</sub>	Output Short Circuit Current	-	-	-	24	mA
<b>LVDS RX</b>						
V <sub>ID</sub>	Input Differential Voltage	-	100	-	600	mV
V <sub>ICM</sub>	Input Common Mode Voltage	-	100	-	2,000	mV
V <sub>TH</sub>	Differential Input Threshold	-	-100	-	100	mV
I <sub>IL</sub>	Input Leakage Current	-	-	-	20	μA

**Figure 30: LVDS RX I/O Electrical Specification Waveform**

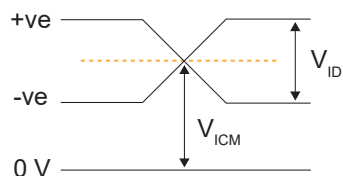

Table 101: LVDS Timing Specifications

Parameter	Description	Min	Typ	Max	Unit
$t_{LVDS\_CPA}$	LVDS TX reference clock phase accuracy	-5	-	+5	%
$t_{LVDS\_skew}$	LVDS TX lane-to-lane skew (edge-aligned)	-	-	200	ps
	LVDS TX lane-to-lane skew (center-aligned)	-	-	250	ps
$t_{LVDS\_SU}$	LVDS RX Data to CLK setup time	344	-	-	ps
$t_{LVDS\_HD}$	LVDS RX Data to CLK hold time	344	-	-	ps

Figure 31: LVDS RX Timing (Center-Aligned)

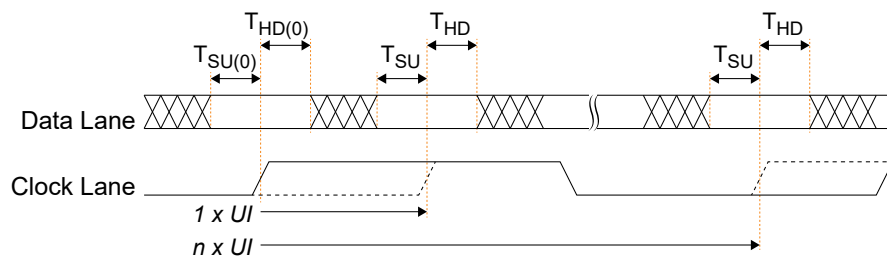
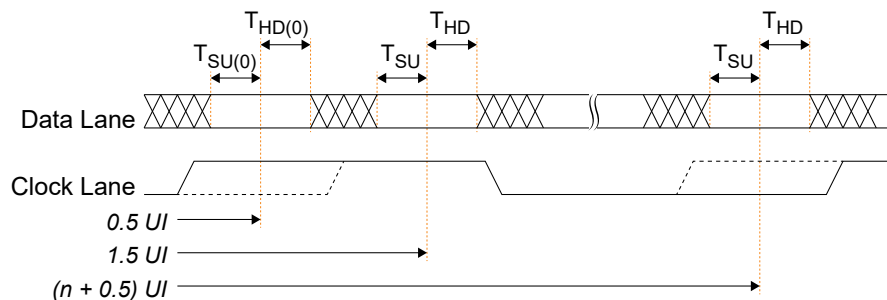

Figure 32: LVDS RX Timing (Edge-Aligned)



## ESD Performance

Refer to the [Trion Reliability Report](#) for ESD performance data.

# MIPI Electrical Specifications and Timing

The MIPI D-PHY transmitter and receiver are compliant to the MIPI Alliance Specification for D-PHY Revision 1.1.

**Table 102: High-Speed MIPI D-PHY Transmitter (TX) DC Specifications**

Parameter	Description	Min	Typ	Max	Unit
$V_{CMTX}$	High-speed transmit static common-mode voltage	150	200	250	mV
$ \Delta V_{CMTX(1,0)} $	$V_{CMTX}$ mismatch when output is Differential-1 or Differential-0	-	-	5	mV
$ V_{OD} $	High-speed transmit differential voltage	140	200	270	mV
$ \Delta V_{OD} $	VOD mismatch when output is Differential-1 or Differential-0	-	-	14	mV
$V_{OHHS}$	High-speed output high voltage	-	-	360	mV
$Z_{OS}$	Single ended output impedance	40	50	60	$\Omega$
$\Delta Z_{OS}$	Single ended output impedance mismatch	-	-	20	%

**Table 103: High-Speed MIPI D-PHY Transmitter (TX) AC Specifications**

Parameter	Description	Min	Typ	Max	Unit
$\Delta V_{CMTX(HF)}$	Common-level variations above 450 MHz	-	-	15	mV <sub>RMS</sub>
$\Delta V_{CMTX(LF)}$	Common-level variations between 50 to 450 MHz	-	-	25	mV <sub>PEAK</sub>
$t_R$ and $t_F$	Rise and fall time < 1.0 Gbps	-	-	0.3	UI
	Rise and fall time > 1.0 Gbps	-	-	0.35	UI
	Rise and fall time > 1.5 Gbps	-	-	0.4	UI

**Table 104: Low-Power MIPI D-PHY Transmitter (TX) DC Specifications**

Parameter	Description	Min	Typ	Max	Unit
$V_{OH}$	Thevenin output high level	0.95	1.2	1.3	V
$V_{OL}$	Thevenin output low level	-50	-	50	mV
$Z_{OLP}$	Output impedance of low-power transmitter	110	-	-	$\Omega$

**Table 105: Low-Power MIPI D-PHY Transmitter (TX) AC Specifications**

Parameter	Description	Min	Typ	Max	Unit
$T_{RLP}/T_{FLP}$	15%-85% rise time and fall time	-	-	25	ns
$T_{REOT}$	30%-85% rise time and fall time	-	-	35	ns
$T_{LP-PULSE-TX}$	Pulse width of first LP exclusive-OR clock pulse after Stop state or last pulse before Stop state	40	-	-	ns
	Pulse width of all other pulses	-	20	-	ns
$T_{LP-PER-TX}$	Period of the LP exclusive-OR clock	90	-	-	ns
$\delta V/\delta t_{SR}$	Slew rate at $C_{LOAD} = 50$ pF < 1.5 Gbps	30	-	150	mV/ns
	Slew rate at $C_{LOAD} = 50$ pF > 1.5 Gbps	25	-	150	mV/ns

**Table 106: High-Speed MIPI D-PHY Receiver (RX) DC Specifications**

Parameter	Description	Min	Typ	Max	Unit
$V_{CMRX(DC)}$	Common mode voltage high-speed receive mode	70	-	330	mV
$Z_{ID}$	Differential input impedance	80	100	120	$\Omega$

**Table 107: High-Speed MIPI D-PHY Receiver (RX) AC Specifications**

Parameter	Description	Min	Typ	Max	Unit
$\Delta V_{CMRX(HF)}$	Common-point interference above 450 MHz	-	-	50	mV
$\Delta V_{CMRX(LF)}$	Common-point interference between 50 MHz to 450 MHz	-	-	25	mV
$V_{IDTH}$	Differential input high threshold	-	-	40	mV
$V_{IDTL}$	Differential input low threshold	-40	-	-	mV
$V_{IHHS}$	Single-ended input high voltage	-	-	460	mV
$V_{ILHS}$	Single-ended input low voltage	-40	-	-	mV
$V_{TERM-EN}$	Single-ended threshold for high-speed termination enable	-	-	450	mV
CCP	Common-point termination	-	-	60	pF

**Table 108: Low-Power MIPI D-PHY Receiver (RX) DC Specifications**

Parameter	Description	Min	Typ	Max	Unit
$V_{IH}$	Logic 1 input voltage	740	-	-	mV
$V_{IL}$	Logic 0 input voltage, not in ULP state	-	-	550	mV
$V_{IL-ULPS}$	Logic 0 input voltage, ULP state	-	-	300	mV
$V_{HYST}$	Input hysteresis	25	-	-	mV

Table 109: Low-Power MIPI D-PHY Receiver (RX) AC Specifications

Parameter	Description	Min	Typ	Max	Unit
$T_{\text{MIN-RX}}$	Minimum pulse width response	20	-	-	ns
$V_{\text{INT}}$	Peak interference amplitude	-	-	200	mV
$f_{\text{INT}}$	Interference frequency	450	-	-	MHz

## MIPI Power-Up Timing

Apply power to  $VCC12A\_MIPIx\_TX$ ,  $VCC12A\_MIPIx\_RX$ , , and  $VCC25A\_MIPIx$  at least  $t_{\text{MIPI\_POWER}}$  after VCC is stable. See **Power Up Sequence** on page 52 for a power-up sequence diagram.

Table 110: MIPI Timing

Symbol	Parameter	Min	Typ	Max	Units
$t_{\text{MIPI\_POWER}}$	Minimum time after VCC is stable before powering MIPI power supplies.	1	-	-	$\mu\text{s}$

## MIPI Reset Timing

The MIPI RX and TX interfaces have two reset signals ( $DPHY\_RSTN$  and  $RSTN$ ) to reset the D-PHY controller logic. These signals are active low, and you should use them together to reset the MIPI interface.

The following waveform illustrates the minimum time required to reset the MIPI interface.

Figure 33: DPHY\_RSTN and RSTN Timing Diagram

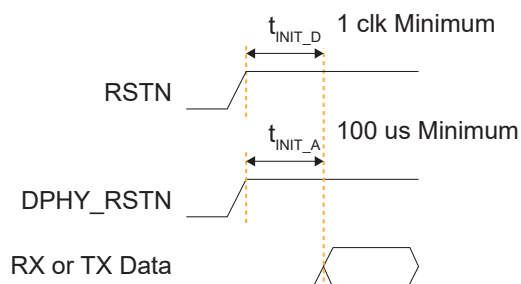

Table 111: MIPI Timing

Symbol	Parameter	Min	Typ	Max	Units
$t_{\text{INIT\_A}}$	Minimum time between the rising edge of $DPHY\_RSTN$ and the start of MIPI RX or TX data.	100	-	-	$\mu\text{s}$
$t_{\text{INIT\_D}}$	Minimum time between the rising edge of $RSTN$ and the start of MIPI RX or TX data.	1	-	-	clk

## PLL Timing and AC Characteristics

The following tables describe the PLL timing and AC characteristics.

**Table 112: PLL Timing (C3, C4, Q4, and I4)**

Symbol	Parameter	Min	Typ	Max	Units
F <sub>IN</sub> <sup>(22)</sup>	Input clock frequency from core.	10	-	330	MHz
	Input clock frequency from GPIO.	10	-	200	MHz
	Input clock frequency from LVDS.	10	-	400	MHz
F <sub>OUT</sub>	Output clock frequency.	0.24	-	500	MHz
F <sub>OUT</sub>	Output clock frequency for PLL BR0 CLKOUT0 (DDR PHY input clock). F324 and F400 packages only.	0.24	-	533	MHz
F <sub>VCO</sub>	PLL VCO frequency for internal feedback mode.	500	-	1,600	MHz
	PLL VCO frequency for local and core feedback mode	500	-	3,600	MHz
F <sub>PLL</sub>	Post-divider PLL VCO frequency if all output divider values ≤ 64	62.5	-	1,800	MHz
	Post-divider PLL VCO frequency if any of the output divider value > 64	62.5	-	1,400	MHz
F <sub>PFD</sub>	Phase frequency detector input frequency.	10	-	100	MHz

**Table 113: PLL Timing (C4L and I4L)**

Symbol	Parameter	Min	Typ	Max	Units
F <sub>IN</sub> <sup>(22)</sup>	Input clock frequency from core.	10	-	330	MHz
	Input clock frequency from GPIO.	10	-	200	MHz
	Input clock frequency from LVDS.	10	-	400	MHz
F <sub>OUT</sub>	Output clock frequency.	0.24	-	500	MHz
F <sub>OUT</sub>	Output clock frequency for PLL BR0 CLKOUT0 (DDR PHY input clock). F324 and F400 packages only.	0.24	-	533	MHz
F <sub>VCO</sub>	PLL VCO frequency for internal feedback mode.	500	-	1,600	MHz
	PLL VCO frequency for local and core feedback mode	500	-	3,200	MHz
F <sub>PLL</sub>	Post-divider PLL VCO frequency if all output divider values ≤ 64	62.5	-	1,600	MHz
	Post-divider PLL VCO frequency if any of the output divider value > 64	62.5	-	1,200	MHz
F <sub>PFD</sub>	Phase frequency detector input frequency.	10	-	100	MHz

<sup>(22)</sup> When using the Dynamic clock source mode, the maximum input clock frequency is limited by the slowest clock frequency of the assigned clock source. For example, the maximum input clock frequency of a Dynamic clock source mode from core and GPIO is 200 MHz.

**Table 114: PLL AC Characteristics**<sup>(23)</sup>

Symbol	Parameter	Min	Typ	Max	Units
t <sub>DT</sub>	Output clock duty cycle.	40	50	60	%
t <sub>OPJIT</sub> (PK - PK) (24)	Output clock period jitter (PK-PK).	-	-	200	ps
t <sub>PLL_HLW</sub>	PLL input clock from GPIO, HIGH/LOW pulse width.	2.25	-	-	ns
	PLL input clock from LVDS, HIGH/LOW pulse width.	1.13	-	-	ns
t <sub>ILJIT</sub> (PK - PK)	Input clock long-term jitter (PK-PK)	-	-	800	ps
t <sub>LOCK</sub>	PLL lock-in time.	-	-	0.5	ms

<sup>(23)</sup> Test conditions at 3.3 V and room temperature.

<sup>(24)</sup> The output jitter specification applies to the PLL jitter when an input jitter of 20 ps is applied.

# Configuration Timing

The T20 FPGA has the following configuration timing specifications. Refer to [AN 006: Configuring Trion FPGAs](#) for detailed configuration information.

**Table 115: Timing Parameters for All Modes (WLCSP80, Q100F3, Q144, F169, and F256 Packages)**

Symbol	Parameter	Min	Typ	Max	Units
t <sub>CRESET_N</sub>	Minimum creset_n low pulse width required to trigger re-configuration.	320	-	-	ns
t <sub>USER</sub>	Minimum configuration duration after CDONE goes high before entering user mode. <sup>(25)(26)</sup> Test condition at 10 kΩ pull-up resistance and 10 pF output loading on CDONE pin.	12	-	(27)	μs

**Table 116: Timing Parameters for All Modes (F324 and F400 Packages)**

Symbol	Parameter	Min	Typ	Max	Units
t <sub>CRESET_N</sub>	Minimum creset_n low pulse width required to trigger re-configuration.	320	-	-	ns
t <sub>USER</sub>	Minimum configuration duration after CDONE goes high before entering user mode. <sup>(25)(26)</sup> Test condition at 10 kΩ pull-up resistance and 10 pF output loading on CDONE pin.	25	-	(27)	μs

<sup>(25)</sup> The FPGA may go into user mode before t<sub>USER</sub> has elapsed. However, Efinix recommends that you keep the system interface to the FPGA in reset until t<sub>USER</sub> has elapsed.

<sup>(26)</sup> For JTAG programming, the min t<sub>USER</sub> configuration time is required after CDONE goes high and FPGA receives the ENTERUSER instruction from JTAG host (TAP controller in UPDATE\_IR state).

<sup>(27)</sup> See [Maximum t<sub>USER</sub> for SPI Active and Passive Modes](#) on page 80

## SPI Active

Figure 34: SPI Active Mode (x1) Timing Sequence

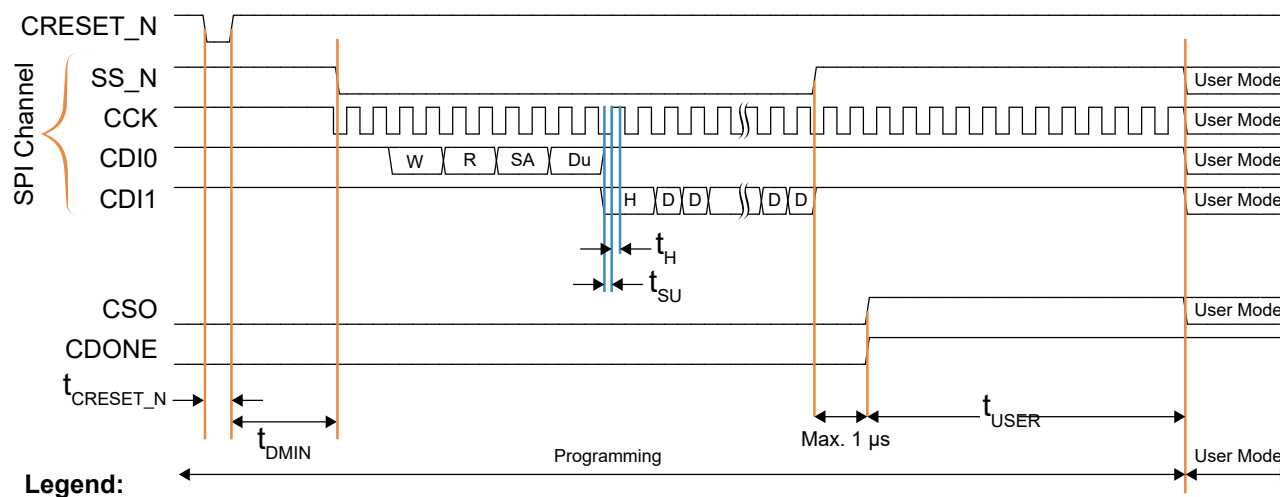

The JTAG pins must be inactive during SPI active configuration.

Table 117: Active Mode Timing Parameters

Symbol	Parameter	Frequency	Min	Typ	Max	Units
$f_{MAX\_M}$	Active mode configuration clock frequency. <sup>(28)</sup>	DIV4 <sup>(29)</sup>	14	20	26	MHz
		DIV8	7	10	13	MHz
$t_{SU}$	Setup time. Test condition at 3.3 V I/O standard and 0 pF output loading.	-	7.5	-	-	ns
$t_H$	Hold time. Test condition at 3.3 V I/O standard and 0 pF output loading.	-	1	-	-	ns
$t_{DMIN}$	Minimum time between deassertion of CRESET_N to first valid configuration data.	-	1.2	-	-	$\mu$ s



**Note:** Refer to **Power Up Sequence** on page 52 for details on the power-up requirements.

<sup>(29)</sup> For Q100F3 packages, the total  $C_{LOAD}$  connected to each SPI pin must be less than 25 pF.

<sup>(28)</sup> For parallel daisy chain x2 and x4, the active configuration clock frequency,  $f_{MAX\_M}$ , must be set to DIV4.

## SPI Passive

Figure 35: SPI Passive Mode (x1) Timing Sequence

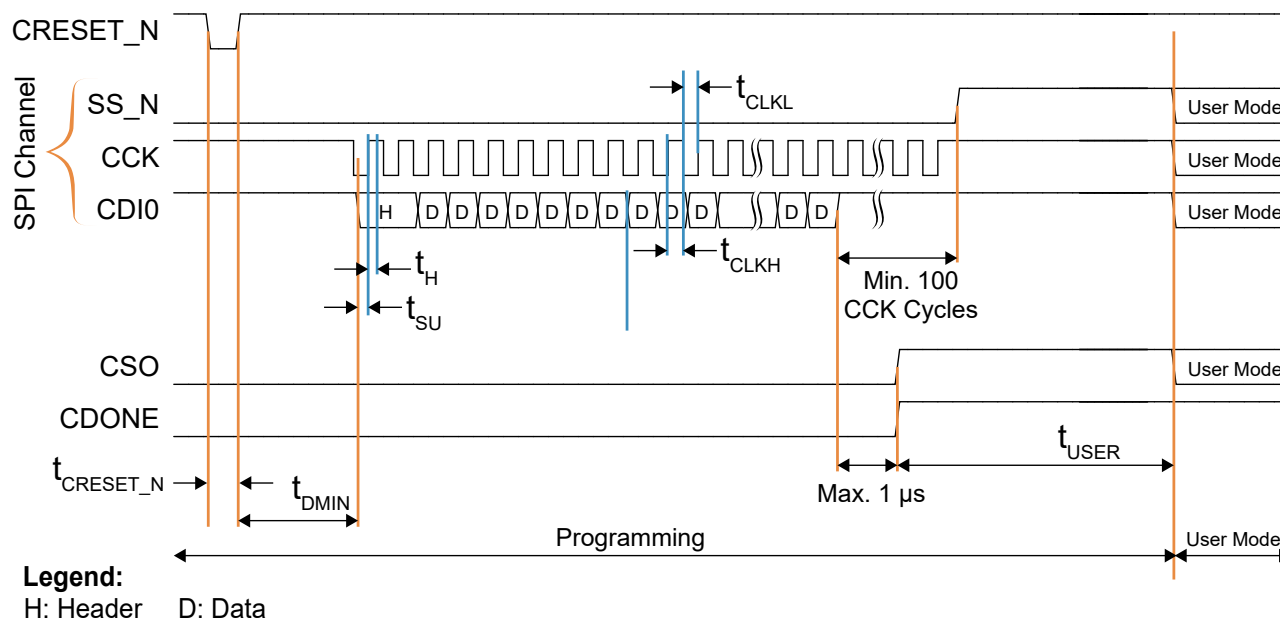

The JTAG pins must be inactive during SPI passive configuration.

Table 118: Passive Mode Timing Parameters (W80, Q100F3, Q144, F169, and F256 Packages)

Symbol	Parameter	Min	Typ	Max	Units
$f_{MAX\_S}$	Passive mode X1 configuration clock frequency.	-	-	25	MHz
	Passive mode X2, X4 or X8 configuration clock frequency.	-	-	50	MHz
	Passive mode X16 or X32 configuration clock frequency.	-	-	100	MHz
$t_{CLKH}$	Configuration clock pulse width high.	$0.48 \cdot 1 / f_{MAX\_S}$	-	-	ns
$t_{CLKL}$	Configuration clock pulse width low.	$0.48 \cdot 1 / f_{MAX\_S}$	-	-	ns
$t_{SU}$	Setup time.	6	-	-	ns
$t_H$	Hold time.	1	-	-	ns
$t_{DMIN}$	Minimum time between deassertion of CRESET_N to first valid configuration data.	1.2	-	-	$\mu$ s

Table 119: Passive Mode Timing Parameters (F324 and F400 Packages)

Symbol	Parameter	Min	Typ	Max	Units
f <sub>MAX_S</sub>	Passive mode X1 configuration clock frequency.	-	-	25	MHz
	Passive mode X2, X4 or X8 configuration clock frequency.	-	-	50	MHz
	Passive mode X16 or X32 configuration clock frequency.	-	-	100	MHz
t <sub>CLKH</sub>	Configuration clock pulse width high.	$0.48 \cdot 1 / f_{MAX\_S}$	-	-	ns
t <sub>CLKL</sub>	Configuration clock pulse width low.	$0.48 \cdot 1 / f_{MAX\_S}$	-	-	ns
t <sub>SU</sub>	Setup time.	6.5	-	-	ns
t <sub>H</sub>	Hold time.	1	-	-	ns
t <sub>DMIN</sub>	Minimum time between deassertion of CRESET_N to first valid configuration data.	1.2	-	-	μs



**Note:** Refer to [Power Up Sequence](#) on page 52 for details on the power-up requirements.

## JTAG

Figure 36: JTAG Programming Waveform (WLCSP80, Q100F3, Q144, F169, and F256 Packages)

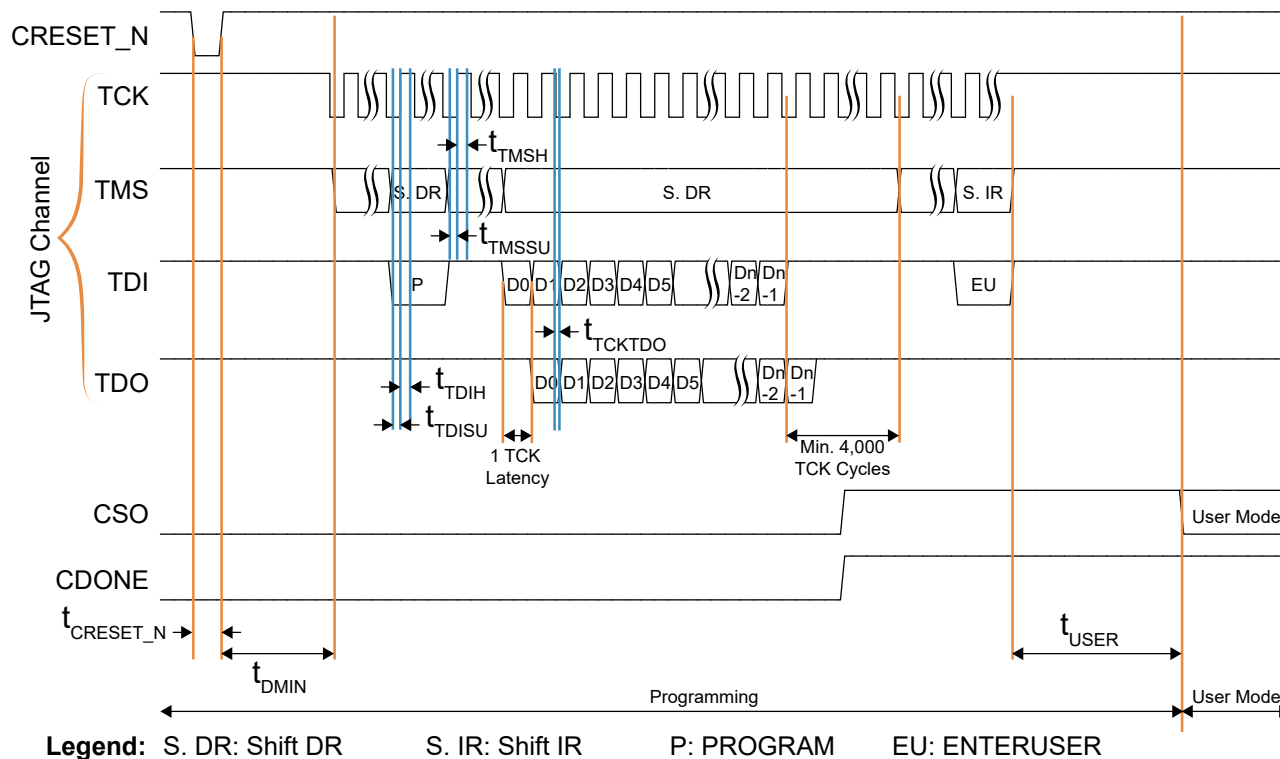

The SPI bus must be inactive during JTAG configuration.



**Important:** Refer to [Power Up Sequence](#) on page 52 for power-up details.

Table 120: JTAG Mode Timing Parameters (W80, Q100F3, Q144, F169, and F256 Packages)

Symbol	Parameter	Min	Typ	Max	Units
$f_{TCK}$	TCK frequency.	-	-	25	MHz
$t_{TDISU}$	TDI setup time.	3.5	-	-	ns
$t_{TDIH}$	TDI hold time.	1	-	-	ns
$t_{TMSU}$	TMS setup time.	3	-	-	ns
$t_{TMSH}$	TMS hold time.	1	-	-	ns
$t_{TCKTDO}$	TCK falling edge to TDO output.	-	-	10.5 <sup>(30)</sup>	ns
$t_{DMIN}$	Minimum time between deassertion of CRESET_N to first valid configuration data.	1.2	-	-	$\mu$ s

<sup>(30)</sup> 0 pf output loading.

Figure 37: JTAG Programming Waveform (F324 and F400 Packages)

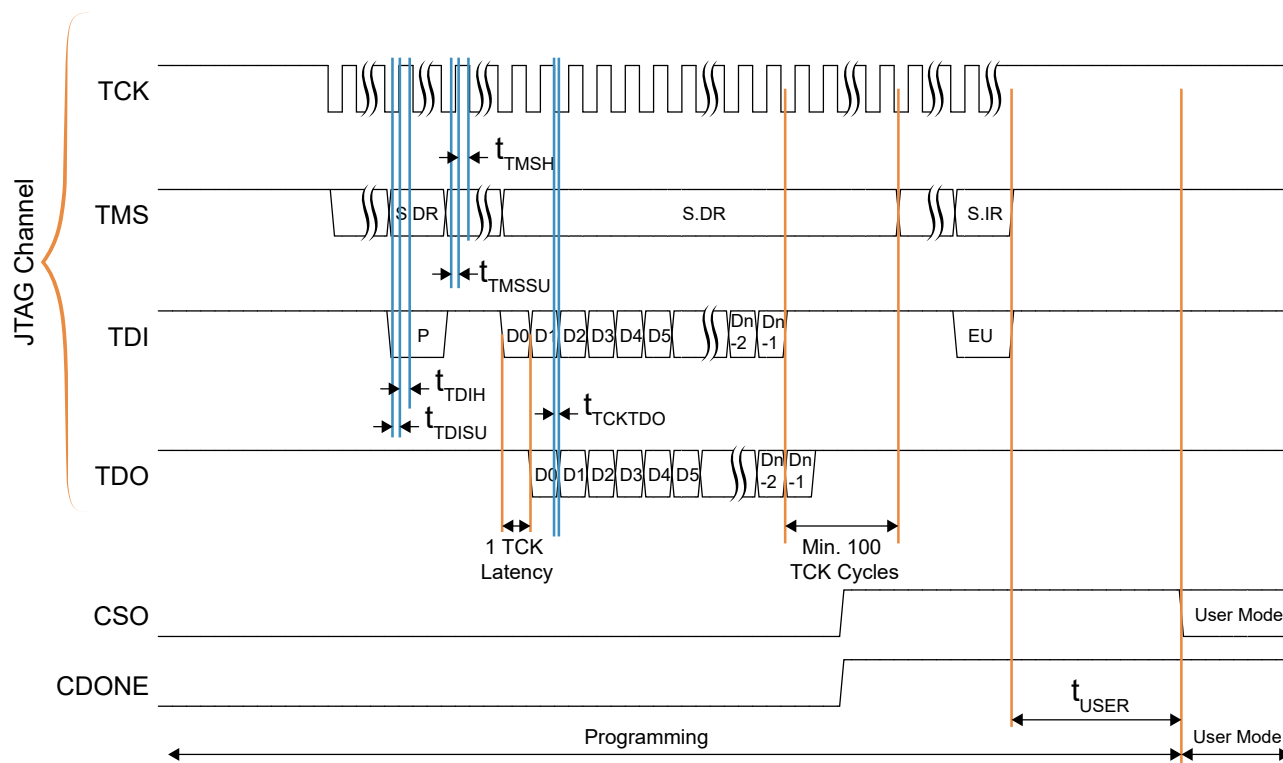
**Legend:**

S. DR: Shift DR      S. IR: Shift IR      P: PROGRAM      EU: ENTERUSER

The SPI bus must be inactive during JTAG configuration.



**Important:** Refer to [Power Up Sequence](#) on page 52 for power-up details.

Table 121: JTAG Mode Timing Parameters (F324 and F400 Packages)

Symbol	Parameter	Min	Typ	Max	Units
$f_{TCK}$	TCK frequency.	-	-	25	MHz
$t_{TDISU}$	TDI setup time.	3.5	-	-	ns
$t_{TDIH}$	TDI hold time.	2.5	-	-	ns
$t_{TMSSU}$	TMS setup time.	3	-	-	ns
$t_{TMSH}$	TMS hold time.	2.5	-	-	ns
$t_{TCKTDO}$	TCK falling edge to TDO output.	-	-	10.5	ns
$t_{DMIN}$	Minimum time between deassertion of CRESET_N to first valid configuration data.	1.2	-	-	$\mu$ s



**Note:** Refer to [Power Up Sequence](#) on page 52 for details on the power-up requirements.

## Maximum $t_{USER}$ for SPI Active and Passive Modes

The following waveform illustrates the minimum and maximum values for  $t_{USER}$ .

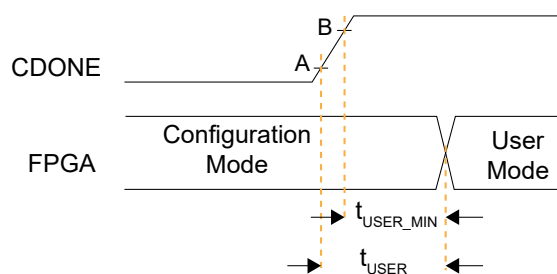

- *Point A*—User-defined trigger point to start counter on  $t_{USER}$
- *Point B*— $V_{IH}$  (with Schmitt Trigger) of Trion I/Os

The maximum  $t_{USER}$  value can be derived based on the following formula:

**Table 122:  $t_{USER}$  Maximum**

Configuration Setup	$t_{USER}$ Maximum
Single Trion FPGA	$t_{USER} = t_{(from\ A\ to\ B)} + t_{USER\_MIN}$
Slave FPGA in a dual-Trion FPGA SPI chain	
Master FPGA in a dual-Trion FPGA SPI chain	$t_{USER} = (1344 / SPI\_WIDTH) * CCK\ period + t_{USER\_MIN} + t_{(from\ A\ to\ B)}$

# Pinout Description

The following tables describe the pinouts for power, ground, configuration, and interfaces.

**Table 123: General Pinouts**

Function	Group	Direction	Description
VCC	Power	-	Core power supply.
VCCA <sub>xx</sub>	Power	-	PLL analog power supply. <i>xx</i> indicates location: TL: Top left, TR: Top right, BR: bottom right
VCCIO <sub>xx</sub>	Power	-	I/O pin power supply. <i>xx</i> indicates the bank location: 1A: Bank 1A, 3E: Bank 3E 4A: Bank 4A (only for 3.3 V), 4B: Bank 4B (only for 3.3 V)
VCCIO <sub>xx_yy_zz</sub>	Power	-	Power for I/O banks that are shorted together. <i>xx</i> , <i>yy</i> , and <i>zz</i> are the bank locations. For example: VCCIO1B_1C shorts banks 1B and 1C VCCIO3C_TR_BR shorts banks 3C, TR, and BR
GND	Ground	-	Ground.
CLK <sub>n</sub>	Alternate	Input	Global clock network input. <i>n</i> is the number. The number of inputs is package dependent.
CTRL <sub>n</sub>	Alternate	Input	Global network input used for high fanout and global reset. <i>n</i> is the number. The number of inputs is package dependent.
PLLIN	Alternate	Input	PLL reference clock resource. There are 5 PLL reference clock resource assignments. Assign the reference clock resource based on the PLL you are using.
MREFCLK	Alternate	Input	MIPI TX PLL reference clock source.
GPIO <sub>x_n</sub>	GPIO	I/O	General-purpose I/O for user function. User I/O pins are single-ended. <i>x</i> : Indicates the bank (L or R) <i>n</i> : Indicates the GPIO number.
GPIO <sub>x_n_yyy</sub> GPIO <sub>x_n_yyy_zzz</sub> GPIO <sub>x_zzzn</sub>	GPIO Multi-Function	I/O	Multi-function, general-purpose I/O. These pins are single ended. If these pins are not used for their alternate function, you can use them as user I/O pins. <i>x</i> : Indicates the bank; left (L), right (R), or bottom (B). <i>n</i> : Indicates the GPIO number. <i>yyy</i> , <i>yyy_zzz</i> : Indicates the alternate function. <i>zzzn</i> : Indicates LVDS TX or RX and number.
TXN <sub>n</sub> , TXP <sub>n</sub>	LVDS	I/O	LVDS transmitter (TX). <i>n</i> : Indicates the number.
RXN <sub>n</sub> , RXP <sub>n</sub>	LVDS	I/O	LVDS receiver (RX). <i>n</i> : Indicates the number.
CLKN <sub>n</sub> , CLKP <sub>n</sub>	LVDS	I/O	Dedicated LVDS receiver clock input. <i>n</i> : Indicates the number.
RXN <sub>n</sub> _EXTFB <sub>n</sub> RXP <sub>n</sub> _EXTFB <sub>n</sub>	LVDS	I/O	LVDS PLL external feedback. <i>n</i> : Indicates the number.
REF_RES	-	-	REF_RES is a reference resistor to generate constant current for LVDS TX. Connect a 12 kΩ resistor with a tolerance of ±1% to the REF_RES pin with respect to ground. If none of the pins in a bank are used for LVDS, leave this pin floating.

**Table 124: Dedicated Configuration Pins**

These pins cannot be used as general-purpose I/O after configuration.

All the pins are in internal weak pull-up during configuration except for TCK and TDO.

Pins	Direction	Description	External Weak Pull-Up/ Pull Down Requirement
CDONE	I/O	Configuration done status pin. CDONE is an open drain output; connect it to an external pull-up resistor to VCCIO. When CDONE = 1, the configuration is complete and the FPGA enters user mode. You can hold CDONE low and release it to synchronize the FPGAs entering user mode.	Pull up
CRESET_N	Input	Active-low FPGA reset and re-configuration trigger. Pulse CRESET_N low for a duration of $t_{\text{creset\_N}}$ before releasing CRESET_N from low to high to initiate FPGA re-configuration. This pin does not perform a system reset.	Pull up
TCK	Input	JTAG test clock input (TCK). The rising edge loads signals applied at the TAP input pins (TMS and TDI). The falling edge clocks out signals through the TAP TDO pin.	Pull up
TMS	Input	JTAG test mode select input (TMS). The I/O sequence on this input controls the test logic operation. The signal value typically changes on the falling edge of TCK. TMS has an internal weak pull-up; when it is not driven by an external source, the test logic perceives a logic 1.	Pull up
TDI	Input	JTAG test data input (TDI). Data applied at this serial input is fed into the instruction register or into a test data register depending on the sequence previously applied at TMS. Typically, the signal applied at TDI changes state following the falling edge of TCK while the registers shift in the value received on the rising edge. Like TMS, TDI has an internal weak pull-up; when it is not driven from an external source, the test logic perceives a logic 1.	Pull up
TDO	Output	JTAG test data output (TDO). This serial output from the test logic is fed from the instruction register or a test data register depending on the sequence previously applied at TMS. The shift out content is based on the issued instruction. The signal driven through TDO changes state following the falling edge of TCK. When data is not being shifted through the device, TDO is set to an inactive drive state (e.g., high-impedance).	Pull up



**Note:** All dedicated configuration pins have Schmitt Trigger buffer. See [Table 73: Single-Ended I/O and Dedicated Configuration Pins Schmitt Trigger Buffer Characteristic](#) on page 58 for the Schmitt Trigger buffer specifications.

**Table 125: Dual-Purpose Configuration Pins**

In user mode (after configuration), you can use these dual-purpose pins as general I/O.

Pins	Direction	Description	Use External Weak Pull-Up
CBUS[2:0]	Input	Configuration bus width select. CBUS has an internal weak pull-up. However, Efinix recommends that you use an external pull-up accordingly. See <i>Selecting the Configuration Mode</i> in <a href="#">AN 006: Configuring Trion FPGAs</a> .	Pull up or pull down <sup>(31)</sup>
CBSEL[1:0]	Input	Multi-image configuration selection pin. This function is not applicable to single-image bitstream configuration or internal reconfiguration (remote update). Connect CBSEL[1:0] to the external resistors for the image you want to use: 00 for image 1 01 for image 2 10 for image 3 11 for image 4 0: Connect to an external weak pull down. 1: Connect to an external weak pull up.	Pull up or pull down <sup>(32)</sup>
CCK	I/O	Passive SPI input configuration clock or active SPI output configuration clock (active low). Includes an internal weak pull-up.   <b>Important:</b> The CCK pin in Q100F3 packages are only available in user mode when the LVDS TX resources are not in use. The CCK pin should not be toggled when any LVDS TX is used.	Optional <sup>(33)</sup>
CDIn	I/O	<i>n</i> is a number from 0 to 31 depending on the SPI configuration. 0: Passive serial data input or active serial output. 1: Passive serial data output or active serial input. <i>n</i> : Parallel I/O. In multi-bit daisy chain connection, the CDI (31:0) connects to the data bus in parallel.	Optional <sup>(33)</sup>
CSI	Input	Chip select. 0: The FPGA is not selected or enabled and will not be configured. 1: Selects the FPGA for all configuration modes. CSI must remain high throughout all configuration modes.	Pull up
CSO	Output	Chip select output. Selects the next device for cascading configuration.	N/A
NSTATUS	Output	Status (active low). Indicates a configuration error. When the FPGA drives this pin low, it indicates either an ID mismatch or a failed bitstream CRC check. Refer to <a href="#">Table 129: I/O Pin States</a> on page 86.	N/A

<sup>(31)</sup> Optional for x1 mode.

<sup>(32)</sup> Not applicable to single-image or remote update.

<sup>(33)</sup> Optional unless pull-up is required by external load.

Pins	Direction	Description	Use External Weak Pull-Up
SS_N	Input	<p>SPI configuration mode select. The FPGA senses the value of SS_N when it comes out of reset (i.e., CRESET_N transitions from low to high).</p> <p>0: SPI Passive mode; connect to external weak pull down.</p> <p>1: SPI Active mode; connect to external weak pull up.</p> <p>In active configuration mode, SS_N is an active-low chip select to the flash device (CDI0 - CDI3).</p>	Optional <sup>(33)</sup>
TEST_N	Input	<p>Active-low test mode enable signal. Set to 1 to disable test mode.</p> <p>During all configuration modes, rely on the external weak pull-up or drive this pin high.</p>	Pull up

**Table 126: MIPI Pinouts (Dedicated)**

*n* Indicates the number. *L* indicates the lane

Function	Group	Direction	Description
VCC25A_MIPI0 VCC25A_MIPI1	Power	-	MIPI 2.5 V analog power supply.
VCC12A_MIPI0_TX VCC12A_MIPI1_TX	Power	-	MIPI 1.2 V TX analog power supply.
VCC12A_MIPI0_RX VCC12A_MIPI1_RX	Power	-	MIPI 1.2 V RX analog power supply.
GNDA_MIPI	Ground	-	Ground for MIPI analog power supply.
MIPI <sub>n</sub> _TXDPL MIPI <sub>n</sub> _TXDNL	MIPI	I/O	MIPI differential transmit data lane.
MIPI <sub>n</sub> _RXDPL MIPI <sub>n</sub> _RXDNL	MIPI	I/O	MIPI differential receive data lane.
MREFCLK	Clock	Input	MIPI PLL reference clock source.

**Table 127: DDR Pinouts (Dedicated)**

*n* indicates the number.

Function	Direction	Description
VCCIO_DDR	-	DDR power supply.
DDR_A[ <i>n</i> ]	Output	Address signals to the memories.
DDR_BA[ <i>n</i> ]	Output	Bank signals to the memories.
DDR_CAS_N	Output	Active-low column address strobe signal to the memories.
DDR_CKE	Output	Active-high clock enable signals to the memories.
DDR_CK DDR_CK_N	Output	Differential clock output pins to the memories.
DDR_CS_N	Output	Active-low chip select signals to the memories.
DDR_DQ[ <i>n</i> ]	I/O	Data bus to/from the memories.
DDR_DM[ <i>n</i> ]	Output	Active-high data-mask signals to the memories.
DDR_DQS_N[ <i>n</i> ]	I/O	Differential data strobes to/from the memories.
DDR_DQS[ <i>n</i> ]	I/O	Differential data strobes to/from the memories.
DDR_ODT	Output	ODT signal to the memories.
DDR_RAS_N	Output	Active-low row address strobe signal to the memories.
DDR_RST_N	Output	Active-low reset signals to the memories.
DDR_WE_N	Output	Active-low write enable strobe signal to the memories.
DDR_VREF	I/O	Reference voltage.
DDR_ZQ	I/O	ZQ calibration pin.

Table 128: SPI Flash Memory Pin

Function	Direction	Description
SPI_CS_N	Input	Active-low internal SPI flash memory chip select. Available in QFP100F3 packages only.

## Pin States

GPIO pins have an internal pull up/down (see [Figure 7: I/O Interface Block](#) on page 15), and LVDS pins used as GPIO have a weak pull up. The following table shows the pin state during reset, configuration, and when unused in user mode.



**Note:** For the DDR pin states, refer to the [Trion DDR DRAM Block User Guide](#).

Table 129: I/O Pin States

Pin Type	During Reset (CRESET_N Low)	During Configuration (CRESET_N High, CDONE Low)	When Unused in User Mode (Default)
User Pins			
GPIO	Input tri-state with weak pull up.	Input tri-state with weak pull up.	Input tri-state with weak pull up. <sup>(34)</sup>
LVDS used as GPIO	Input tri-state with no weak pull up or pull down.	Input tri-state with no weak pull up or pull down.	Input tri-state with weak pull up.
Dual-Purpose Configuration Pins			
CSO	0	0 <sup>(35)</sup>	Input tri-state with weak pull up.
NSTATUS	1	1 <sup>(36)</sup>	Input tri-state with weak pull up.
CCK	Input tri-state with weak pull up.	SPI active output clock. SPI passive input with weak pull up.	Input tri-state with weak pull up.
CDI0	Input tri-state with weak pull up.	SPI active output. SPI passive input with weak pull up.	Input tri-state with weak pull up.

As shown in [Power Up Sequence](#) on page 52, CRESET\_N must be kept low during power up.



**Note:** Refer to the following tables for details:

[Table 75: Single-Ended I/O Internal Weak Pull-Up and Pull-Down Resistance](#) on page 58

[Table 91: Single-Ended I/O Internal Weak Pull-Up and Pull-Down Resistance](#) on page 64

<sup>(34)</sup> You can change it to weak pull-down in the Interface Designer.

<sup>(35)</sup> CSO is driven to 1 when the bitstream is done transmitting (CDONE = 1).

<sup>(36)</sup> NSTATUS is driven to 0 if the FPGA detects an invalid bitstream (e.g., CRC error).

# Efinity Software Support

The Efinity<sup>®</sup> software provides a complete tool flow from RTL design to bitstream generation, including synthesis, place-and-route, and timing analysis. The software has a graphical user interface (GUI) that provides a visual way to set up projects, run the tool flow, and view results. The software also has a command-line flow and Tcl command console. The Efinity<sup>®</sup> software supports simulation flows using the ModelSim, NCSim, or free iVerilog simulators. An integrated hardware Debugger with Logic Analyzer and Virtual I/O debug cores helps you probe signals in your design. The software-generated bitstream file configures the T20 FPGA. The software supports the Verilog HDL, SystemVerilog, and VHDL languages.

# T20 Interface Floorplans



**Note:** The numbers in the floorplan figures indicate the GPIO and LVDS number ranges. Some packages may not have all GPIO or LVDS pins in the range bonded out. Refer to the **T20 Pinout** for information on which pins are available in each package.

Figure 38: Floorplan Diagram for FPGAs in W80 Packages (with MIPI)

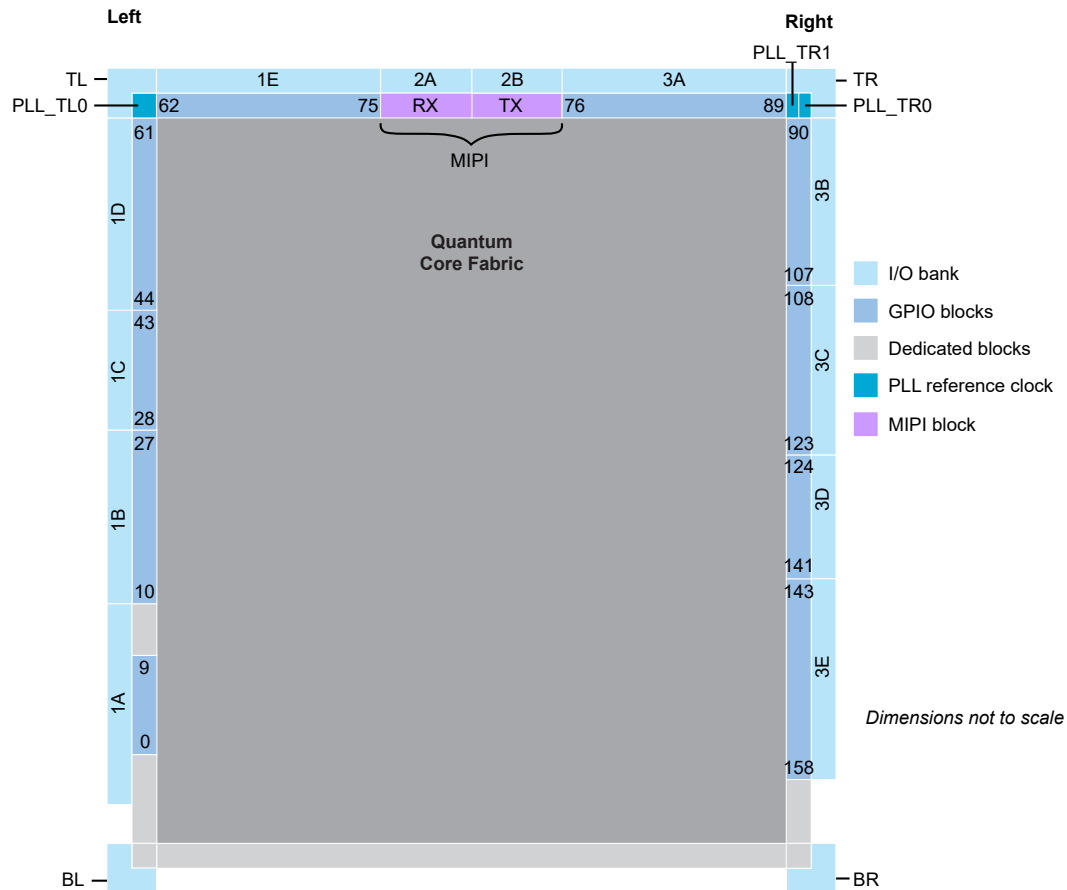

Figure 39: Floorplan Diagram for Q100F3 and Q144 Packages

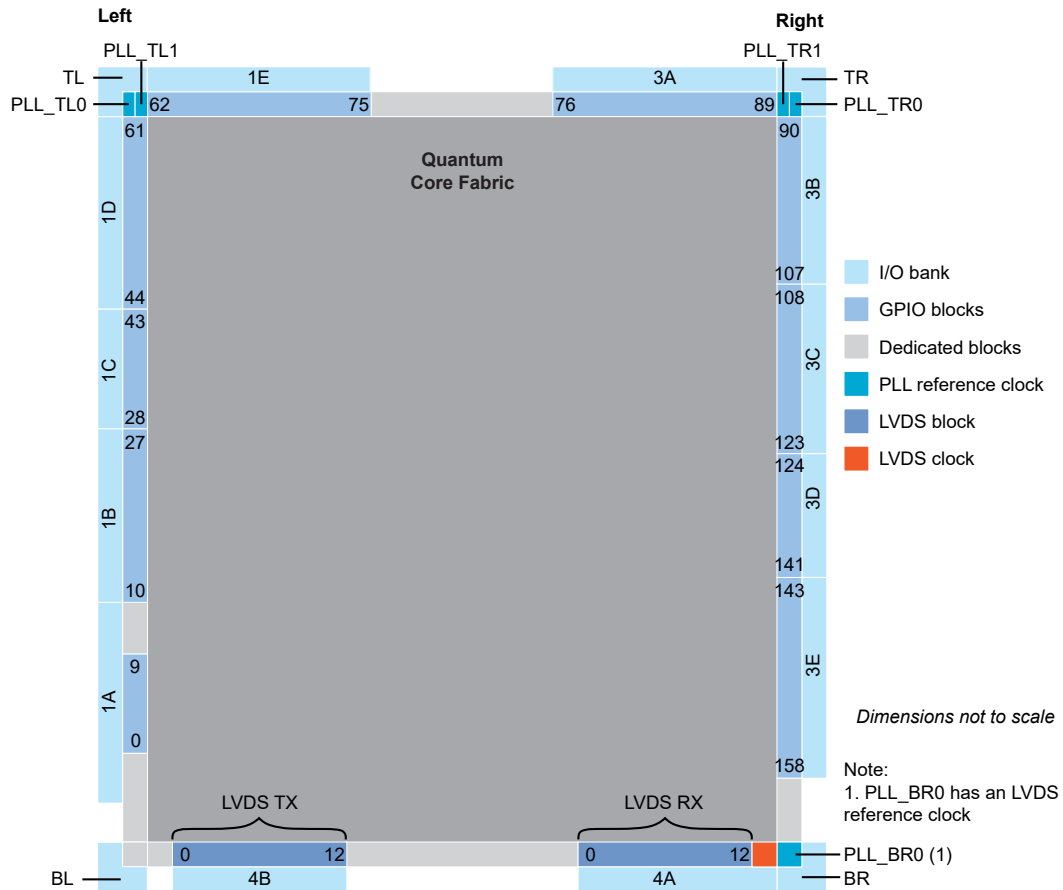

Figure 40: Floorplan Diagram for FPGAs in F169 Packages (with MIPI)

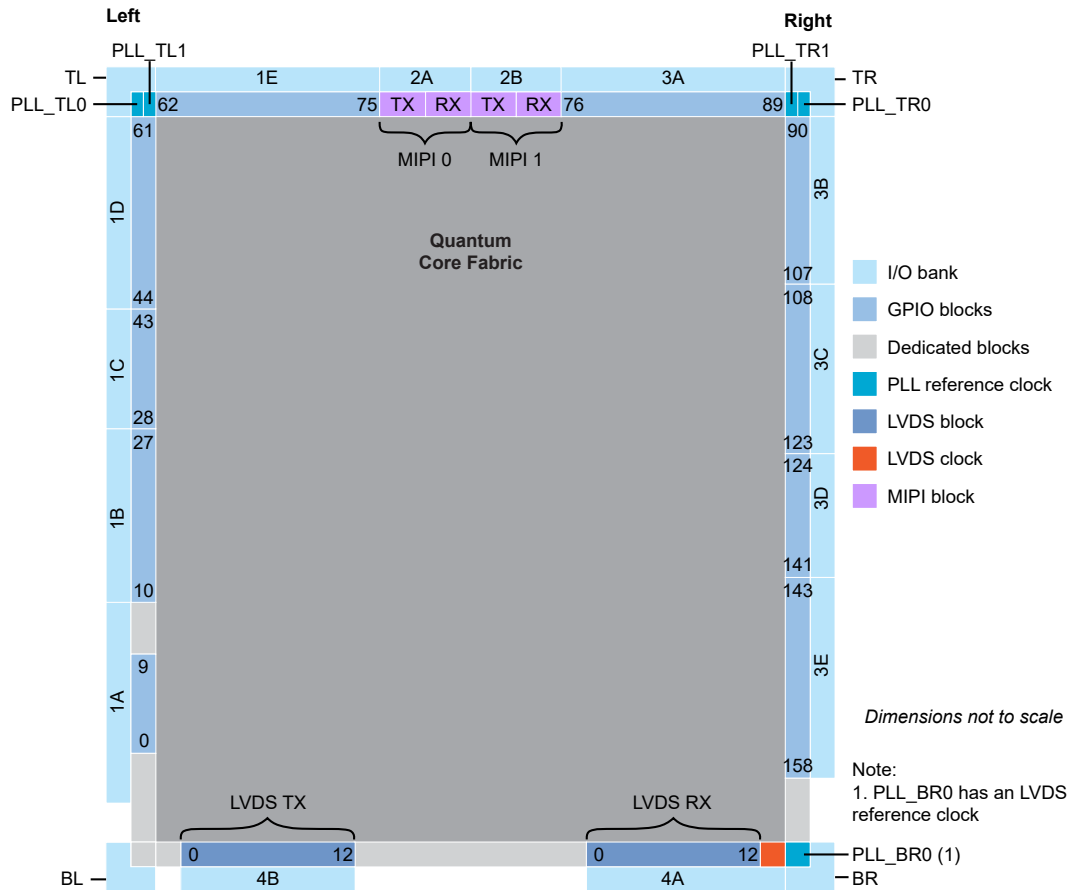

Figure 41: Floorplan Diagram for FPGAs in F256 Packages

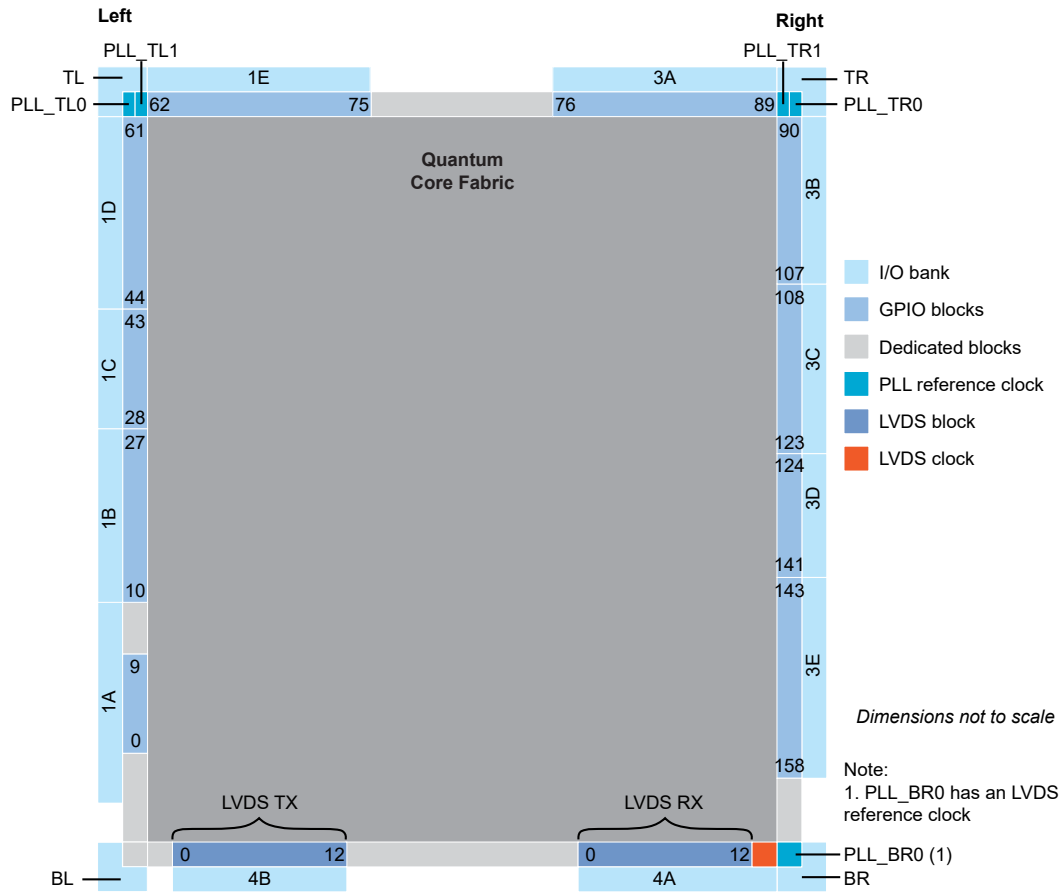

Figure 42: Floorplan Diagram for FPGAs in F324 Packages (with DDR and MIPI)

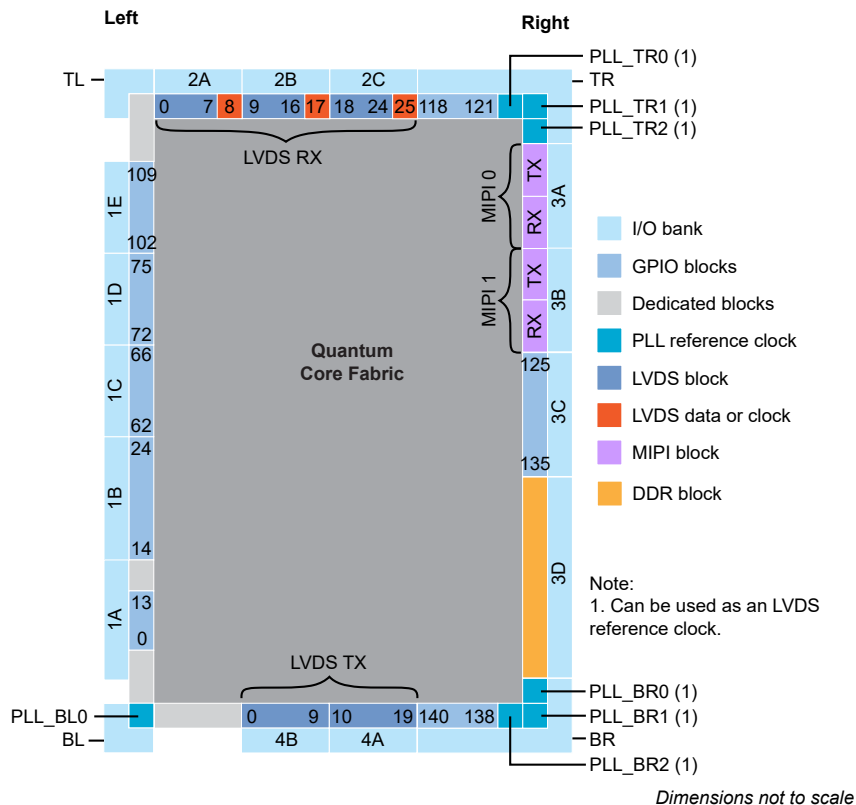
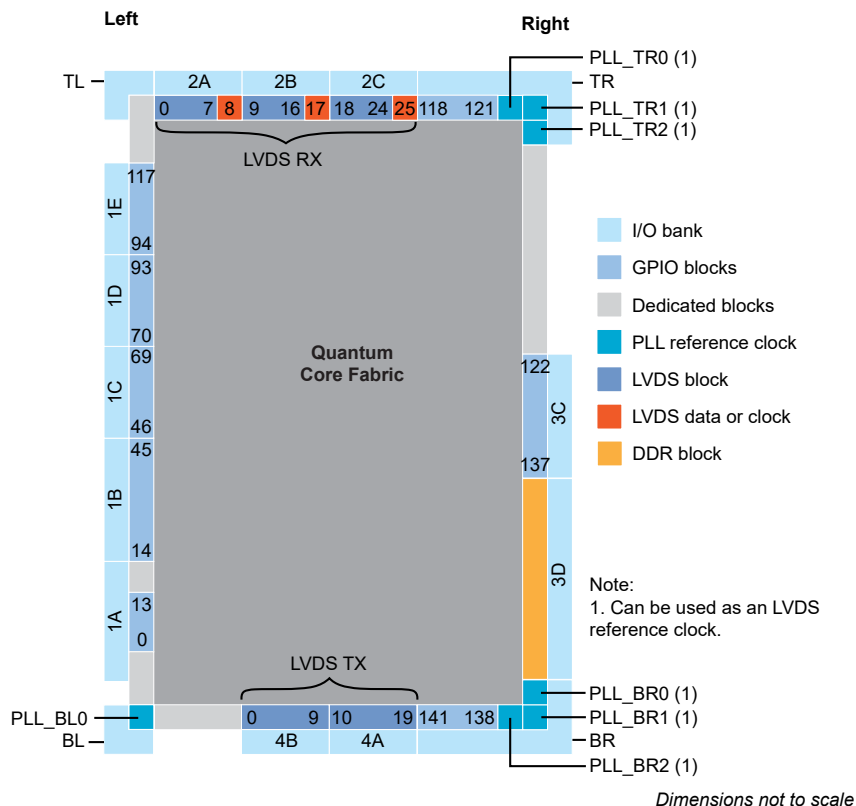

Figure 43: Floorplan Diagram for FPGAs in F400 Packages (with DDR)



# Ordering Codes

Refer to the [Trion Selector Guide](#) for the full listing of T20 ordering codes.

# Revision History

Table 130: Revision History

Date	Version	Description
November 2025	6.0	<p>Added details about the maximum clock rate for the SPI flash device in QFP100F3 packages.</p> <p>Updated <b>Unused Resources and Features</b> on page 53. (DOC-2610)</p> <p>Updated <b>SPI Flash Memory</b> on page 50.</p> <p>Updated CBSEL[1:0] in <b>Table 125: Dual-Purpose Configuration Pins</b> on page 83.</p>
April 2025	5.10	<p>Fixed typo in <b>Table 117: Active Mode Timing Parameters</b> on page 75. (DOC-2500)</p>
April 2025	5.9	<p>Correction to <b>MIPI Power-Up Timing</b> on page 71.</p> <p>Updated LVDS used as GPIO state in Pin States topic.</p> <p>Updated configuration timing waveforms. (DOC-2325)</p> <p>Corrected MIPI reset timing diagram. (DOC-2323)</p> <p>Moved information about unused resources to <b>Unused Resources and Features</b> on page 53.</p>
November 2024	5.8	<p>Fixed typo in <b>Table 125: Dual-Purpose Configuration Pins</b> on page 83. (DOC-2038)</p> <p>Footnote added to <b>Table 17: PLL Signals (Interface to FPGA Fabric)</b> on page 20. (DOC-1939)</p> <p>Corrected merged banks for F324 package (see <b>I/O Banks</b> on page 18).</p> <p>Updated GPIO interface pin names (IN to I and OUT to O). (DOC-2086)</p> <p>Removed Dynamic Enable Pin Name from <b>Table 29: LVDS RX Settings in Efinity Interface Designer</b> on page 27. Pin does not exist in Trion family. (PT-2355)</p> <p>Added Pin States topic. (DOC-2087)</p> <p>SPI and JTAG pins should not be active at the same time for configuration. (DOC-2046)</p> <p>Renamed package prefix to match Efinity software (e.g., BGA changed to F).</p>
February 2024	5.7	<p>Updated SPI passive timing waveform.</p> <p>Added note about external DC-biased circuit is required if the incoming LVDS signals are AC-coupled and link to Trion Hardware Design Checklist and Guidelines. (DOC-1532)</p> <p>MIPI D-PHY specification is v1.1. (DOC-1610)</p>
October 2023	5.6	<p>Added note about maximum <math>C_{LOAD}</math> for SPI pins for DIV4 SPI active mode in QFP100F3 packages. (DOC-1423)</p>
October 2023	5.5	<p>Added LVDS RX Static Mode Delay Setting. (DOC-1473)</p> <p>Updated the characterized load in Maximum Toggle Rate table. (DOC-1468)</p> <p>Updated 2.5 V and 1.8 LVCMOS Single-Ended I/O Internal Weak Pull-Up and Pull-Down Resistance. (DOC-1476)</p> <p>Updated absolute maximum ratings for VCCIO1A_1B_1C and <math>T_J</math>, removed preliminary notes, and updated SPI flash block topic for in QFP100F3 packages. (DOC-1503)</p>

Date	Version	Description
September 2023	5.4	Updated maximum LVDS toggle rate for QFP144 and QFP100F3 packages. (DOC-1447) Updated CCK pin description. (DOC-1447)
June 2023	5.3	Updated SPI Flash Memory Signals table.
June 2023	5.2	Removed $t_{LVDS\_DT}$ and $t_{INDT}$ specs, and replaced with $t_{PLL\_HLW}$ and $t_{LVDS\_CPA}$ . (DOC-1189) Updated PLL LOCKED signal description. (DOC-1208) Corrected $t_{CLKH}$ and $t_{CLKL}$ in F324 and F400 SPI Passive specs, and $f_{TCK}$ in WLCSP80, QFP100F3, QFP144, F169, and F256 JTAG specs. (DOC-1304)
April 2023	5.1	Added support for Q100F3 packages. Corrected $t_{LVDS\_SU}$ and $t_{LVDS\_HD}$ specs (DOC-1070) Updated PLL RSTN signal description about de-asserting only when CLKIN is stable. (DOC-1226)
February 2023	5.0	Updated $t_{LVDS\_skew}$ specs. (DOC-1111) Updated $t_{LVDS\_SU}$ specs (DOC-1070) Updated power up sequence diagram. (DOC-954) Added note to use LVDS blocks from the same side to minimize skew. (DOC-1150) Updated Advanced PLL Settings table descriptions. (DOC-945)
November 2022	4.9	Added note recommending up to only 2 cascading PLLs. (DOC-931) Corrected $I_{OH}$ and $I_{OL}$ in buffer drive strength characteristic specifications. (DOC-933) Updated $F_{VCO}$ , $F_{PLL}$ , and $F_{PFD}$ PLL Timing parameter specifications and PLL Interface Designer Settings - Manual Configuration Tab notes. (DOC-1019) Added $t_{LVDS\_SU}$ , $t_{LVDS\_HD}$ specs and LVDS RX timing waveforms.
September 2022	4.8	Removed PLL_EXTFB from alternative input. (DOC-849) Updated output clock frequency for BR0 CLKOUT0 specs. (DOC-271) Updated Advanced PLL LOCKED signal description. (DOC-763)
April 2022	4.7	Added note about not using LVDS RX as a reference clock resource to drive the PLL BR0. (DOC-768) Updated test condition load to maximum load in Maximum Toggle Rate Table. (DOC-781) Updated Connection Requirements for Unused Resources table by specifying VCC value. (DOC-770) Updated note about leaving at least 2 pairs of unassigned LVDS pins between any GPIO and LVDS in the same device side. (DOC-769)
March 2022	4.6	Corrected $t_H$ and $t_{SU}$ parameter label in SPI Passive Mode (x1) Timing Sequence figure. Updated behaviour description for GPIO and LVDS as GPIO pins during configuration, and unused GPIO pins during user mode. (DOC-720) Added note about the block RAM content is random and undefined if it is not initialized. (DOC-729) Updated DDR description in features list. (DOC-733) Updated power supply ramp rate and power up sequence diagram. (DOC-631)
January 2022	4.5	Added LVDS Pins Configured as Single-Ended I/O Buffer Drive Strength Characteristics for WLCSP80, QFP144, F169, and F256 packages.
January 2022	4.4	Corrected power supply ramp rate. (DOC-699)

Date	Version	Description
January 2022	4.3	<p>Removed LVDS Pins Configured as Single-Ended I/O Buffer Drive Strength Characteristics for WLCSP80, QFP144, F169, and F256 packages. (DOC-679)</p> <p>Added Output Differential Voltage with Reduce VOD Swing option enabled specs. (DOC-648)</p> <p>Added maximum I/O pin input current, <math>I_{IN}</math>, and maximum per bank specs. (DOC-652)</p> <p>Added PLL input clock duty cycle, <math>t_{INDT}</math>, specs. (DOC-661)</p> <p>Updated CDONE pin direction as bidirectional. (DOC-672)</p>
November 2021	4.2	<p>Added storage temperature, <math>T_{STG}</math> spec. (DOC-560)</p> <p>Updated maximum JTAG mode TCK frequency, <math>f_{TCK}</math>. (DOC-574)</p> <p>Updated CSI pin description. (DOC-546)</p> <p>Updated LVDS Pins Configured as Single-Ended I/O Buffer Drive Strength specifications. (DOC-578)</p> <p>Update LVDS standard compliance which is TIA/EIA-644. (DOC-592)</p> <p>Updated <math>t_{CLKH}</math> and <math>t_{CLKL}</math>, and corrected SPI Passive Mode (x1) Timing Sequence waveform. (DOC-590)</p> <p>Updated REF_RES_xx description. (DOC-602, DOC-605)</p> <p>Updated Maximum Toggle Rate table. (DOC-630)</p> <p>Updated minimum Power Supply Ramp Rates. (DOC-631)</p>
September 2021	4.1	<p>Added Single-Ended I/O and LVDS Pins Configured as Single-Ended I/O Rise and Fall Time specs. (DOC-522)</p> <p>Added note to Active mode configuration clock frequency stating that for parallel daisy chain x2 and x4 configuration, <math>f_{MAX_M}</math>, must be set to DIV4. (DOC-528)</p> <p>Added Global Clock Location topic. (DOC-532)</p> <p>Added Maximum <math>t_{USER}</math> for SPI Active and Passive Modes topic. (DOC-535)</p>
August 2021	4.0	<p>Added internal weak pull-up and pull-down resistor specs. (DOC-485)</p> <p>Updated table title for Single-Ended I/O Schmitt Trigger Buffer Characteristic. (DOC-507)</p> <p>Added note in Pinout Description stating all dedicated configuration pins have Schmitt Trigger buffer. (DOC-507)</p> <p>Added QFP144 package option. (DOC-497)</p>
June 2021	3.10	Updated CRESET_N pin description. (DOC-450)
April 2021	3.9	<p>Updated PLL specs; <math>t_{LJIT}</math> (PK - PK) and <math>t_{DT}</math>. (DOC-403)</p> <p>Added note stating C3, C4, and C4L speed grades are not available in WLCSP80 package.</p> <p>Added note about limiting number of LVDS as GPIO output and bidirectional per I/O bank to avoid switching noise. (DOC-411)</p>
March 2021	3.8	Added LVDS TX reference clock output duty cycle and lane-to-lane skew specs. (DOC-416)
March 2021	3.7	Added automotive speed grade (Q4) specs for F169 package. (DOC-399)
February 2021	3.6	<p>Corrected LVDS TX Settings in Efinity® Interface Designer Output Load default value. (DOC-375)</p> <p>Updated Density parameter description and added 256Mb to choice to LPDDR2 in DDR Interface Designer Settings. (DOC-377)</p> <p>Added I/O input voltage, <math>V_{IN}</math> specification. (DOC-389)</p> <p>Added LVDS TX data and timing relationship waveform. (DOC-359)</p> <p>Added LVDS RX I/O electrical specification waveform. (DOC-346)</p>

Date	Version	Description
December 2020	3.5	<p>Added data for C4L and I4L DC speed grades.</p> <p>Added WLCSP80 package option. (DOC-330)</p> <p>Updated the notes for Output Load parameter in LVDS TX Settings in Efinity Interface Designer. (DOC-309)</p> <p>Added a table to Power Up Sequence topic describing pin connection when PLL, GPIO, MIPI, or DDR is not used. (DOC-325)</p> <p>Updated NSTATUS pin description. (DOC-335)</p> <p>Updated PLL reference clock input note by asking reader to refer to PLL Timing and AC Characteristics. (DOC-336)</p> <p>Added other PLL input clock frequency sources in PLL Timing and AC Characteristics. (DOC-336)</p> <p>Removed OE and RST from LVDS block as they are not supported in software. (DOC-328)</p> <p>For the DDR reference clock, the software issues a warning (instead of error) if you do not connect the reference clock to an I/O pad. (DOC-264)</p>
September 2020	3.4	<p>Updated pinout links.</p> <p>Corrected speed grades for single-ended I/O and LVDS configured as single-ended I/O <math>f_{MAX}</math>.</p>
August 2020	3.3	<p>Update MIPI TX and RX Interface Block Diagram to include signal names.</p> <p>Updated REF_CLK description for clarity.</p>
August 2020	3.3	<p>Updated <math>t_{USER}</math> timing parameter values and added a note about the conditions for the values.</p> <p>Updated description for GPIO pins state during configuration to exclude LVDS as GPIO.</p> <p>Added <math>f_{MAX}</math> for single-ended I/O and LVDS configured as single-ended I/O.</p> <p>Added maximum power supply current transient during power-up.</p> <p>Correct the VDDIO_DDR to VCCIO_DDR.</p>

Date	Version	Description
July 2020	3.2	<p>Removed preliminary note from DC and switching characteristics and MIPI electrical specifications and timing. These specifications are final.</p> <p>Added VDDIO_DDR absolute maximum ratings.</p> <p>Added VDDIO_DDR recommended operating conditions.</p> <p>Updated timing parameter symbols in boundary scan timing waveform to reflect JTAG mode parameter symbols.</p> <p>Added table of supported GPIO features.</p> <p>Updated the maximum <math>F_{VCO}</math> for PLL to 1,600 MHz.</p> <p>Updated the C divider requirement for the 90 degrees phase shift in the PLL Interface Designer Settings - Manual Configuration Tab.</p> <p>Updated the DDR DRAM reset signal from RST_N to CFG_RST_N.</p> <p>Corrected DDR DRAM block diagram by adding DDR_CK signal.</p> <p>Updated minimum setup time for passive configuration mode for F324 package to 6.5 ns.</p> <p>Renamed TL_CORNER, BL_CORNER, TR_CORNER, and BR_CORNER as TL, BL, TR, and BR respectively.</p> <p>Updated LVDS electrical specifications note about RX differential I/O standard support and duplicated the note in LVDS functional description.</p> <p>Added note to LVDS RX interface block diagram.</p> <p>Removed all instances of DDR3U.</p> <p>Added note about MIPI power recommended power-up sequence.</p> <p>Updated power up sequence description about holding CRESET_N low.</p> <p>Updated floorplan diagram for FPGAs in F324 and F400 packages.</p> <p>Added I/O bank information for F400 package.</p> <p>Renamed PLLCLK pin as PLL_CLKIN.</p> <p>Added PLL_EXTFB and MIPI_CLKIN as an alternative input in GPIO signals table for complex I/O buffer.</p> <p>Updated PLL names in PLL reference clock resource assignments.</p> <p>Added PLL reference clock resource assignments for F400 package.</p> <p>Updated Memory CAS Latency (CL) choices in Advanced Options tab - Memory Mode register settings subtab.</p> <p>Updated Output Drive Strength choices for LPDDR2 in Advanced Options tab - Memory Mode register settings subtab.</p> <p>Corrected Enable Target 1 parameter notes in AXI 0 and AXI 1 tabs.</p> <p>Removed restriction on CLKOUT1 and CLKOUT2 when CLKIN is used to drive the DDR on CLKOUT0 in DDR DRAM PHY signals table.</p> <p>Added note stating that low core leakage current (6.7 mA typical) is applicable to F256 package only.</p> <p>Updated available GPIO, global clocks from GPIO pins, and global controls from GPIO pins for F400 package.</p> <p>Updated typical leakage current to 6.8 mA and add a note stating it is applicable to F256 package.</p>

Date	Version	Description
February 2020	3.1	<p>Added <math>f_{MAX}</math> for DSP blocks and RAM blocks.</p> <p>Added JTAG timing parameters for T20 FPGAs in F324 packages.</p> <p>In MIPI RX and TX interface description, updated maximum data pixels for RAW10 data type.</p> <p>Added MIPI reset timing information.</p> <p>Added Trion power-up sequence. MIPI power-up moved to this topic.</p> <p>VCC12A_MIPI_TX, VCC12A_MIPI_RX maximum recommended operating condition changed to 1.25 V.</p> <p>Added a note to the Supported Configuration Modes topic to clarify that T20 F324 FPGAs do not support multi-image configuration in SPI active x1 mode.</p> <p>Added the maximum PLL output clock speed for PLL BR0 CLKOUT0 (DDR PHY input clock).</p> <p>Corrected the read and write signal directions in the DDR block diagram.</p> <p>Corrected write strobe bus width.</p> <p>Added number of global clocks and controls that can come from GPIO pins to package resources table.</p>
December 2019	3.0	<p>Updated DDR block description.</p> <p>Updated PLL Interface Designer settings.</p> <p>Removed MIPI data type bit settings. Refer to AN 015: Designing with the Trion MIPI Interface for the bit settings.</p> <p>Removed DIV1 and DIV2 active mode configuration frequencies; they are not supported.</p> <p>Added note to LVDS electrical specifications about RX differential I/O standard support.</p>
October 2019	2.1	<p>Added explanation that 2 unassigned pairs of LVDS pins should be located between and GPIO and LVDS pins in the same bank.</p> <p>Updated the reference clock pin assignments for TL_PLL0 and TL_PLL1.</p> <p>Added waveforms for configuration timing.</p> <p>Clarified I/O bank information.</p>
August 2019	2.0	<p>Updated MIPI interface description.</p> <p>Under Ordering Codes, added link to Trion FPGA Selector Guide.</p>
May 2019	1.0	<p>Updated MIPI description, DC characteristics, and pin information.</p> <p>Updated DDR description.</p> <p>Updated timing specifications.</p> <p>Added information on the signal interface.</p>
January 2019	0.5	<p>Added information on DDIO support.</p>
December 2018	0.4	<p>Updated package options.</p>
November 2018	0.3	<p>Added GND<sub>A_xx</sub> (PLL analog ground) to pinout.</p> <p>Change VSS<sub>xxA_MIPI</sub> pinout to GND<sub>xxA_MIPI</sub>.</p> <p>Updated PLL block diagram and clarified feedback paths.</p> <p>Added floorplan information.</p> <p>Updated pinout table.</p>
October 2018	0.2	<p>Updated I/O logic and buffer topic for DDR mode.</p> <p>Updated LVDS serialization factors.</p> <p>Indicated which I/O banks support DDR mode.</p>
October 2018	0.1	<p>Initial release.</p>