

MIPI AND LVDS EXPANSION DAUGHTER CARD

CONTENTS

PAGE 01 - TABLE OF CONTENTS
PAGE 02 - BLOCK DIAGRAM
PAGE 03 - QTE to 2.54MM HEADER CONVERTER

REVISION HISTORY

1.0 4/17/2020 KCLEE Initial Creation (Originate
from Document ESTB-00002-2)

Efinix 900 Lafayette St, Suite 406 Santa Clara, CA 95050			
Copyright (c) 2019 All Rights Reserved			
Title			
TABLE OF CONTENTS			
Size	Document Number	Rev	
	ETSB-00013-2	1.0	
Date: Thursday, December 17, 2020			
		Sheet	1 of 3



Efinix 900 Lafayette St, Suite 406 Santa Clara, CA 95050			
Copyright (c) 2019 All Rights Reserved			
Title			
BLOCK DIAGRAM			
Size	Document Number	Rev	
	ETSB-00013-2	1.0	
Date:	Friday, April 17, 2020	Sheet	2 of 3

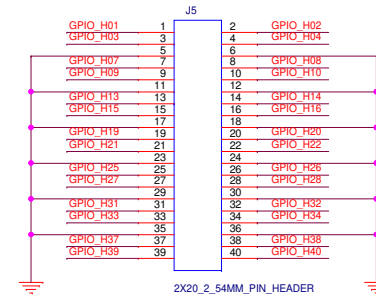
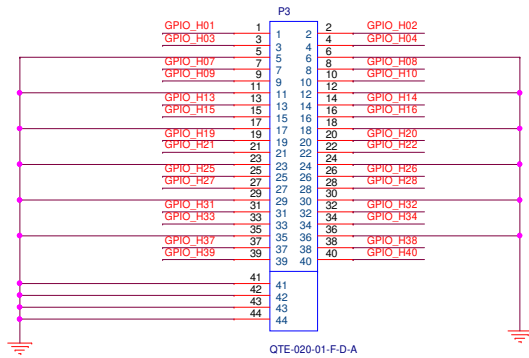



Item	Quantity	Reference	Part	Datasheet	Description	PCB Footprint	Brand	Manufacturer Part No
1	1	J5	2X20 2.54MM PIN HEADER	E0004	2 x 20 Header (2.54 MM Pitch)	Thru-Hole	MULTICOMP	2213S-40G
2	1	P3	QTE-020-01-F-D-A	A0100/A0100-1	40 Ways Board to Board & Mezzanine Connectors 0.80 mm Q Strip High-Speed Ground Plane Terminal Strip	SMD	Samtec	QTE-020-01-F-D-A



Disclaimers

EFINIX DOES NOT PROVIDES ANY WARRANTY OF ACCURACY, COMPLETENESS, MERCHANTABILITY OR NONINFRINGEMENT OF THIRD-PARTY RIGHTS ON THIS DOCUMENT. THE INFORMATION IN THIS DOCUMENT IS "AS IS". IN NO EVENT WILL EFINIX BE LIABLE FOR ANY EXEMPLARY, SPECIAL, CONSEQUENTIAL, INDIRECT, OR INCIDENTAL DAMAGES, INCLUDING ANY LOSS OF DATA, LOST OF PROFITS, LOSS OF INFORMATION, LOSS OF LIFE OR BUSINESS INTERRUPTION, ARISING FROM YOUR USE OF THIS DOCUMENT.

EFINIX shall make changes to this document at any time without notification. EFINIX assumes no obligation to correct any errors contained in this document or to advise any user of this document of any correction if such be made. EFINIX advise its customers obtain the latest FPGA schematic before ordering so that no conflict of information correctness afterward.