



AN 062: Example Design: Video Streaming Over 10 Gigabit Ethernet

AN062-v1.1
December 2024
www.efinixinc.com



Contents

- Introduction..... 3**
- Hardware Requirements.....3**
- Example Design.....3**
- Setting Up the Hardware..... 4**
- Running the Example Design.....5**
 - Network Configuration..... 10
- Restoring the Demonstration Design..... 15**
- Revision History.....15**

Introduction

This example design demonstrates video streaming from the Titanium Ti375 N1156 Development Board to a Windows- or Linux-based computer over 10 Gigabit Ethernet. The example includes a Python program that receives UDP packets from the Titanium Ti375 N1156 Development Board and displays them in a GUI window. This GUI includes various controls that, when set, cause the Python application return the UDP packets to the Titanium Ti375 N1156 Development Board to update the values.

Hardware Requirements

The Titanium Ti375 N1156 Development Kit already includes:

- Titanium Ti375 N1156 Development Board preloaded with a demonstration design
- USB Type-C to Type-A cable
- 12 V, 6.25 A universal power adapter with 5.5 mm DC power converter
- Cooling fan
- Thermal pad
- Jumpers
- 4 standoffs

You will also need the following additional hardware for this demonstration:

- Windows- or Linux-based computer with a 10 gigabit Ethernet SFP+ port
- Dual Raspberry Pi Camera Connector Daughter Card
- Raspberry Pi v3 camera module
- 2 × SFP+ optical modules (10 Gigabit each)
- Fiber-optic cable
- 15-pin flat cable

Example Design

The block diagram below shows the data flow in the example design. All processing and network stacks are implemented in RTL to ensure maximum throughput. There are two types of packets: pixel data and vertical sync. Pixel data is sent to the computer line by line. Any data packets larger the maximum value defined by the user are divided into smaller

packets. Vertical sync packets tell the computer when a frame has ended. The output video is in uncompressed RGB888 format.

Figure 1: Design Data Flow

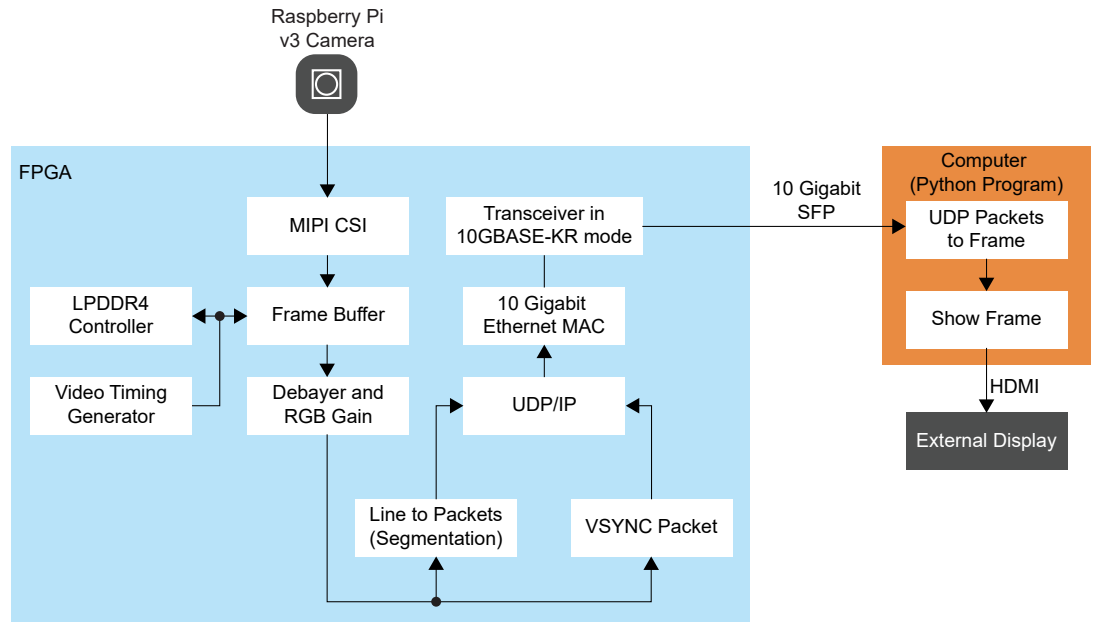

The example design includes a RISC-V Sapphire SoC. With the SoC, you can configure the hardware and change various parameters/settings, such as the IP address or video timing, without the need to recompile the FPGA design. The following diagram shows the interconnections between the SoC and the overall design. In addition, the GUI window includes several sliders that can be used to control some of the parameters of the design.

Figure 2: SoC Connections

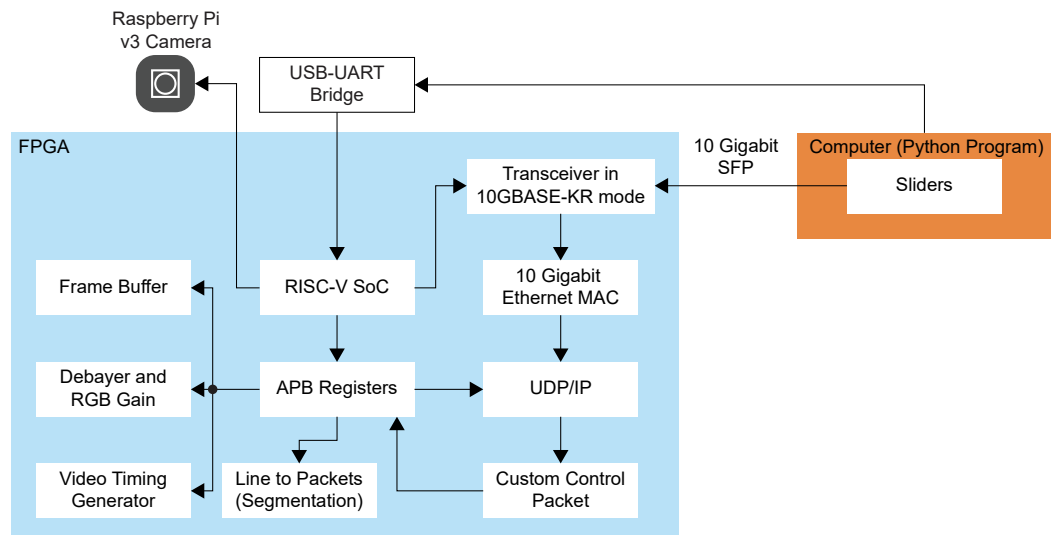

Setting Up the Hardware

Follow these steps to setup your hardware for the demonstration design:

1. Ensure that the jumpers are set as per the following table:

Table 1: Jumper Settings

Header	Pins to Short
J7	5-6
	7-8
J6	5-6
	7-8
J18	5-6
	7-8

2. Connect the Raspberry Pi v3 camera module to the FPC2 connector of the Dual Raspberry Pi Camera Connector Daughter Card.
3. Attach the Dual Raspberry Pi Camera Connector Daughter Card to the P4 header of the Titanium Ti375 N1156 Development Board.
4. Connect the fiber-optic cable to the optical modules.
5. Insert one of the optical modules into the SFP+ port J9 of the Titanium Ti375 N1156 Development Board.
6. Insert another optional module into the computer's SFP+ port.
7. Connect the USB header on the Titanium Ti375 N1156 Development Board to a USB port on your computer
8. Ensure the 12V power adapter is turned off, then connect it to J1 port on the Titanium Ti375 N1156 Development Board.

Figure 3: Visual Overview of Hardware Setup

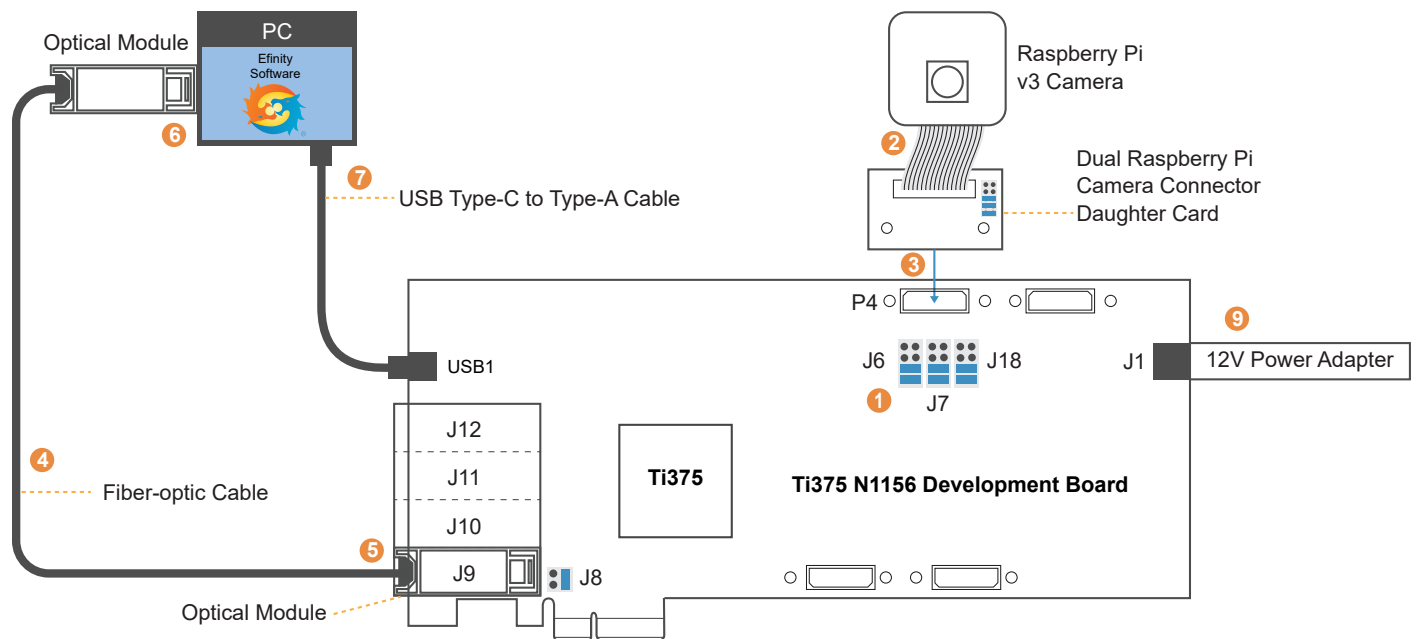

Running the Example Design

Follow these steps to run the example design. These steps assume that you know how to use the Efinity Programmer to download a bitstream to the Titanium Ti375 N1156 Development

Board. For more advice on how to use the Efinity Programmer, see the [Efinity Programmer User Guide](#).

1. This example requires the Efinity software v2024.2 (or later). Efinity patches are available via the [Efinix Support Center](#).
2. Download the example design files from the website ([available here](#)), then extract them.
3. Download the bitstream file, **prebuilt/videostream_combined.hex**, to your Titanium Ti375 N1156 Development Board using the Programmer.
 - a. Choose **SPI Active via JTAG bridge (new) mode**.
 - b. Set the **Starting Flash Address** to 0x0.
4. Change the 10G network interface of your computer to manual mode, then configure it as follows:
 - IP address: 172.16.100.10
 - Netmask: 255.255.255.0
 - Gateway: leave empty



Learn more: For advice on how to change your network interface, see [Network Configuration](#) on page 10.

5. Enable Jumbo Packet support or set the MTU of your computer's network interface to 9000. The example design hardcodes the MTU to 9000 to maximize performance. You can override this in the RISC-V application.
 - If using Windows:
 - a. Open the **Device Manager**.
 - b. Find your 10G network controller in **Network Adapters**.
 - c. Right click, then click **Properties**.
 - d. In the **Advanced** tab, click **Jumbo Packet**.
 - e. Set the **Value** to **9014 Bytes**.

Figure 4: Network Adapter Properties in Windows Device Manager

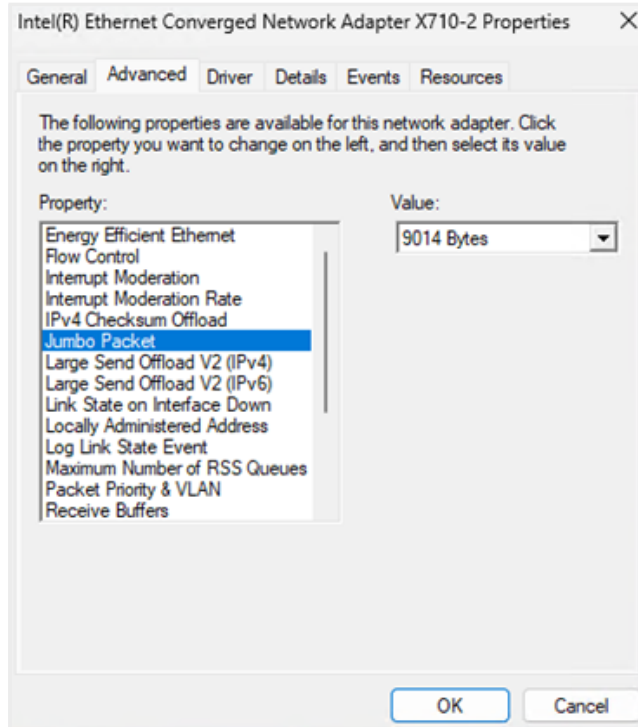

- If using Linux:
 - a. Use the command `sudo ip link set mtu 9000 <INTERFACE>`
 - b. Replace `<interface>` with the name of the network connected to the Titanium Ti375 N1156 Development Board. See the following example:

```
$ sudo ip link set mtu 9000 enpls0f1np1
$ ip a | grep enpls0f1np1
4: enpls0f1np1: <BROADCAST,MULTICAST,UP,LOWER_UP> mtu 9000 qdisc mq
state UP group default quen 1000 inet 172.168.100.10/24 scope global
enpls0f1np1
$ █
```



Note: If you need to override your design's hardcoded MTU, you will need to modify the source code per the following steps:

- a. Navigate to `<project>/sw/sapphire/software/standalone/app/src/apb3reg.c`.
- b. Open the function `reg_init()`.
- c. Modify the value of the register `REG_MSS`.
- d. Recompile the application.
- e. Load the application into the development board.



Learn more: For further guidance on programming and recompiling, see the [Sapphire RISC-V SoC Hardware and Software User Guide](#).

6. If you are using Linux, use the command `sudo sysctl -w net.core.rmem_max=16777216` to set the maximum socket receive buffer size to 16 MB. This setting will reset to the default after rebooting your computer.
7. If your computer is behind a firewall:
 - Create an inbound rule to open UDP port 1235.
 - Create an outbound rule to open UDP port 1236.



Note: If you are using Windows, an error alert Windows Defender Firewall has blocked some features of this app may pop-up when you run the Python program for the first time. Click **Allow access** so that you do not have to modify the firewall rules manually.

8. Power cycle the Titanium Ti375 N1156 Development Board. The LEDs on the Titanium Ti375 N1156 Development Board light up to indicate the board's status:

Table 2: LED Light Up Sequence

LED	Status
LED7 turned on	Power good.
LED8 turned on	FPGA configuration done.
LED1 turned on	LPDDR4 configuration done.
LED2 blinking	The Titanium Ti375 N1156 Development Board is receiving video frames from the camera module.
LED3 blinking	The frame buffer is outputting video frames.
LED4 blinking	MAC is sending Ethernet frames to the transceiver.
LED5 blinking	The Titanium Ti375 N1156 Development Board is receiving Ethernet frames.

9. Open a command prompt (Windows) or terminal (Linux).
10. Change directory to **scripts**.
11. Use command `python -m pip install -r requirements.txt` to install dependencies.
 - **Windows:** If you are using the version of Python that comes bundled with the Efinity software, use the following commands:

```
<PATH_OF_EFINITY>/bin/setup.bat
python3 -m pip install -r requirements.txt
```

- **Linux:** If you are using the version of Python that comes bundled with the Efinity software, use the following commands:

```
source <PATH_OF_EFINITY>/bin/setup.sh
python3 -m pip install -r requirements.txt
```

12. Use command `python showVideo.py` to run the Python program. It will create a window to display the video being streamed from the Titanium Ti375 N1156 Development Board. The default resolution and frame rate is 1920×1080 at 30 fps.

Figure 5: Example Streaming Video

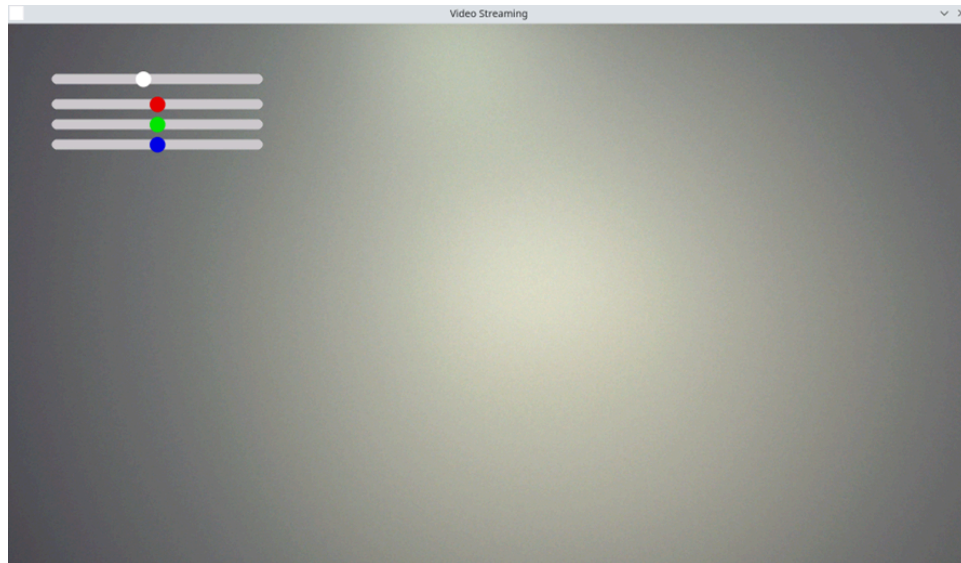

There are four sliders in the top left corner of the window, as shown above. From top to bottom, they control digital gain, red gain, green gain, and blue gain.

13. The Python program also prints the current frame rate every second at the command prompt (Windows) or terminal (Linux).

```
$ python showVideo.py
pygame 2.6.0 (SDL 2.28.4, Python 3.10.14)
Hello from the pygame community. https://www.pygame.org (contribute.html)
socket buffer size: 33554432
interval of a frame: 805.9123ms. Frame rate: 1.24fps
pygame surface size: (1080, 1920)
interval of a frame: 33.3653ms. Frame rate: 29.97fps
interval of a frame: 33.3648ms. Frame rate: 29.97fps
interval of a frame: 33.3649ms. Frame rate: 29.97fps
interval of a frame: 33.3649ms. Frame rate: 29.97fps
interval of a frame: 33.3651ms. Frame rate: 29.97fps
interval of a frame: 33.3649ms. Frame rate: 29.97fps
interval of a frame: 33.3652ms. Frame rate: 29.97fps
interval of a frame: 33.3648ms. Frame rate: 29.97fps
interval of a frame: 33.3645ms. Frame rate: 29.97fps
interval of a frame: 33.3649ms. Frame rate: 29.97fps
interval of a frame: 33.3648ms. Frame rate: 29.97fps
interval of a frame: 33.3650ms. Frame rate: 29.97fps
interval of a frame: 33.3651ms. Frame rate: 29.97fps
interval of a frame: 33.3652ms. Frame rate: 29.97fps
interval of a frame: 33.3647ms. Frame rate: 29.97fps
interval of a frame: 33.3647ms. Frame rate: 29.97fps
interval of a frame: 33.3651ms. Frame rate: 29.97fps
```

14. To change the resolution and frame rate:
- Open terminal software on the computer. You can use any Windows or Linux terminal application, such as PuTTY, Tera Term, Minicom, and others.
 - Select the available USB serial COM port and set the following:
 - Baud rate: 115200
 - Data: 8-bit
 - Parity bit: No
 - Stop bit: 1
15. There are four available resolution and frame rate settings. You can type 0, 1, 2, or 3 to choose the one you want to try. Note that a higher resolution and frame rate

will consume more bandwidth and CPU resources. Packets loss may occur on some computers.

```

initialized!
Camera initialized
user timer initialized!
pic initialized
Interrupt initialized
-----
Choose resolution and frame rate:
0: 1920x1080 @ 30FPS
1: 1920x1080 @ 60FPS
2: 3840x2160 @ 24FPS
3: 3840x2160 @ 30FPS

```

Network Configuration

This section explains how to set your computer's network interface manually.

Network Configuration in Linux



Note: The steps needed to set the IP address differ across various Linux distributions. Therefore, we outline two methods for setting the IP address. Your choice of method should be guided by your Linux distribution.

Network Configuration Method

1. If using a network configuration file to configure your network, open the `/etc/network/interfaces` file with root permission.
2. Add the following configuration:

```

auto <interface>
iface <interface> inet static
address 172.16.100.10/24
mtu 9000

```

Example:

```

auto enpls0f1np1
iface enpls0f1np1 inet static
    address 172.16.100.10/24
    mtu 9000

```

Network Manager GUI Method

The following steps are for the Ubuntu 22.04 distribution.

1. Click the \odot symbol in the top-right corner.

- Choose the 10G network name from the **Wired Connected** menu. The **Wired** dialog box opens with the network settings.

Figure 6: Network Configuration in Ubuntu

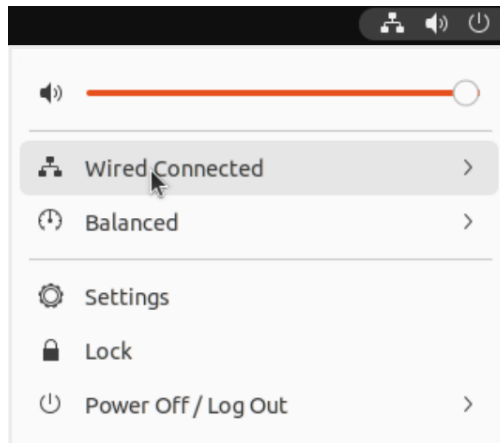

- In the IPv4 tab, change the IPv4 method to **Manual**.
- Set the IP address and netmask per the example below:

Figure 7: IPv4 Manual Configuration in Ubuntu

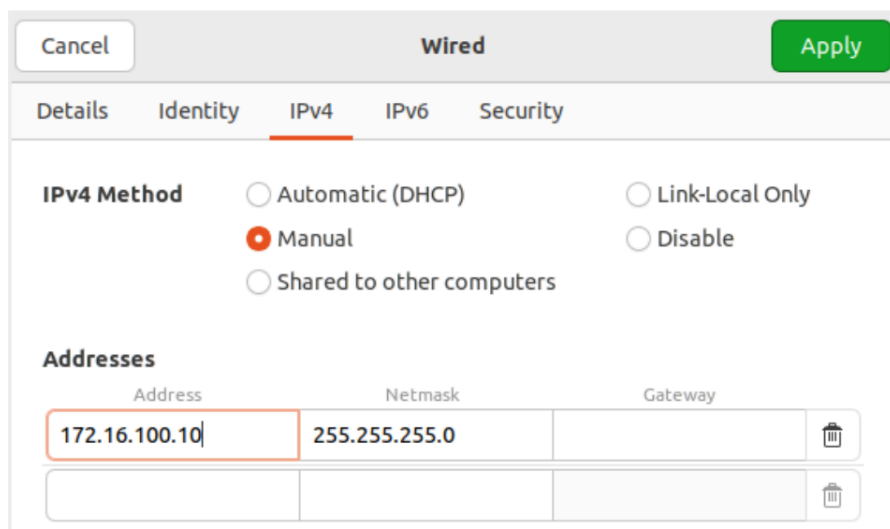

Network Configuration in Windows

Windows 11

- Right-click on the network icon  in the bottom-right corner, and click **Network & Internet Settings**.
- Select **Ethernet** from the menu.

3. Click **Edit**. The **Edit IP settings** dialog box opens.

Figure 8: Edit Ethernet Settings

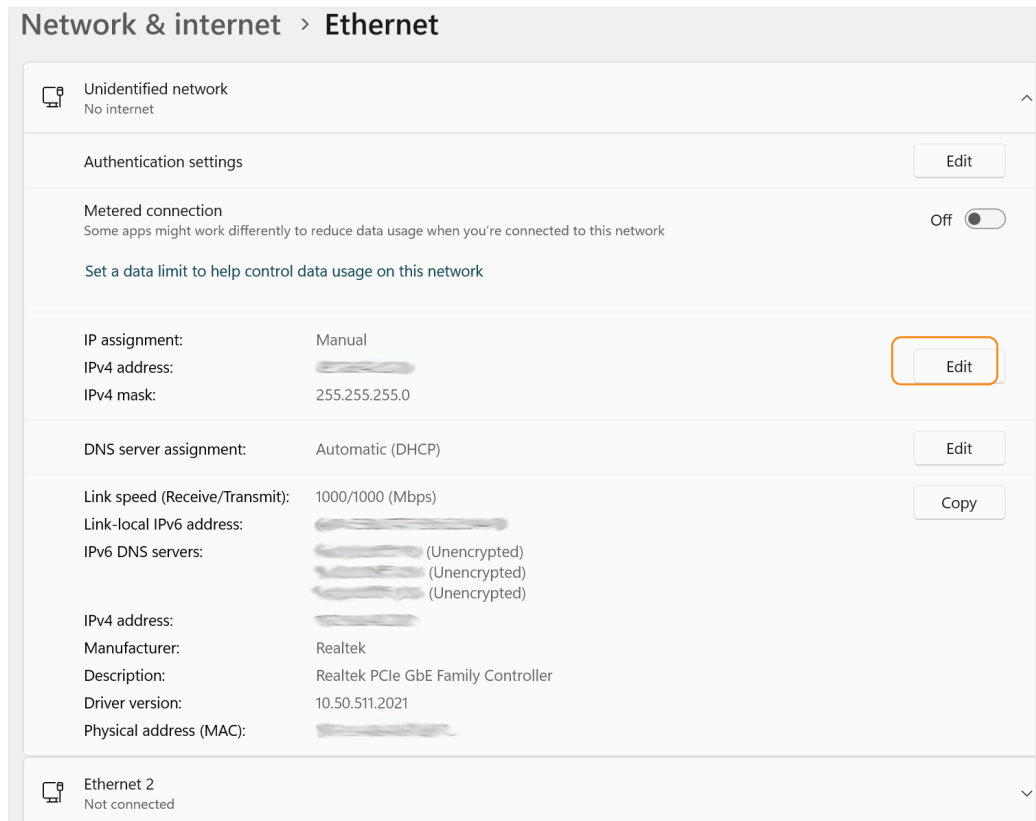

4. Change the settings as indicated:
 - IP address: 172.16.100.10
 - Netmask: 255.255.255.0

- Gateway: leave empty

Figure 9: Edit IP Settings

Edit IP settings

Manual

IPv4

On

IP address

172.16.100.10

Subnet mask

255.255.255.0

Gateway

Preferred DNS

DNS over HTTPS

Off

Alternate DNS

Save Cancel

5. Click **Save**.

Windows 10

1. Right-click on the network icon  in the bottom-right corner, then click **Network & Internet Settings**.
2. Click **Change Adapter Options**.
3. Find the 10G network device. Right click the 10G network name. From the pop-up menu, choose **Properties**.
4. Choose **Internet Protocol Version 4 (TCP/IPv4)**.

5. Click **Properties**.

Figure 10: Windows 10 IPv4 Properties

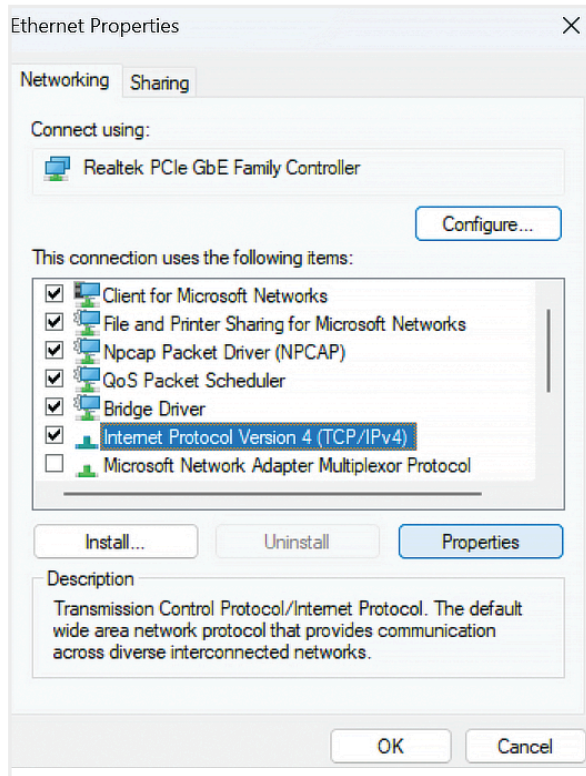

6. Change the settings as indicated:

Figure 11: Windows 10 IP Address Settings

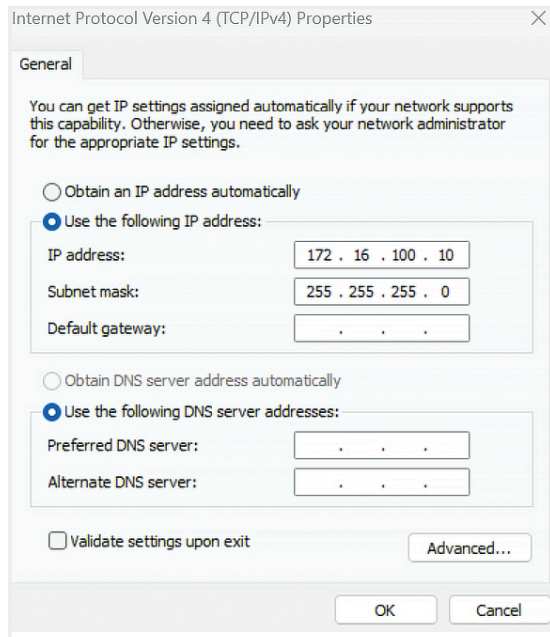

7. Click **OK**.

Restoring the Demonstration Design

After you have used the board for other designs, you may want to go back to the original pre-loaded example design. The preloaded example design project file is available in the [Titanium Ti375 N1156 Development Board Demonstration Design](#) page. To restore the example design, you need to program the board's SPI flash device with the Ti375 FPGA's example design bitstream.



Note: The example design available in the Support Center requires Efinity software v2024.2 or later.

The example design zip file includes a bitstream file to get you started quickly. Download it to the board using these steps:

1. Download the file **video_streaming_10g_demo_v1.2.zip** from the Support Center.
2. Open the project **videostream.xml** in the Efinity software. The project is located in the **fpga/Ti375N1156-DK** directory.
3. Connect the Titanium Ti375 N1156 Development Board to your computer using a USB cable.
4. Go to Efinity Programmer to download the bitstream file, **prebuilt/videostream_combined.hex**, to your board using the **SPI Active using JTAG Bridge (new)** mode. Set the **Starting Flash Address** to **0x000000**.

Revision History

Table 3: Document Revision History

Date	Version	Description
December 2024	1.1	Updated Efinity requirements in line with v1.3 demonstration files.
November 2024	1.0	Initial release.