



AN 048: Performing Boundary-Scan Testing on Titanium FPGAs

AN048-v1.9
July 2025
www.efinixinc.com



Contents

- Introduction..... 3**
- JTAG Pins..... 4**
- TAP Controller..... 5**
- Instruction Register..... 6**
 - Titanium Family JTAG Device IDs..... 7
- Data Registers..... 7**
- Boundary-Scan Register..... 8**
 - HVIO Pins..... 8
 - HSIO Pins..... 9
- Boundary-Scan Testing..... 12**
 - HVIO Pins..... 12
 - HSIO Pins..... 12
 - Dedicated Configuration Pins..... 12
 - Dedicated MIPI Pins..... 13
- Boundary-Scan Description Language..... 13**
- Timing Parameters..... 13**
- Revision History..... 14**

Introduction

The Efinix® Titanium FPGAs support the Joint Test Action Group (JTAG) IEEE Std. 1149.1 Boundary-Scan Testing (BST). BST allows you to test pin connections without physically probing the specific pin, which is beneficial when there is a need to perform a pin connection test quickly and efficiently.

Titanium FPGAs include the following required IEEE Std. 1149.1 circuitry components:

- *JTAG pins*—BST interface
- *TAP Controller*—Controls the BST operation based on the Test Access Port (TAP) Controller State Machine
- *Instruction Register*—Registers for reading and decoding BST instructions
- *Data Registers*—Device ID, bypass, and boundary-scan registers

Figure 1: IEEE Std. 1149.1 Circuitry in Titanium FPGAs

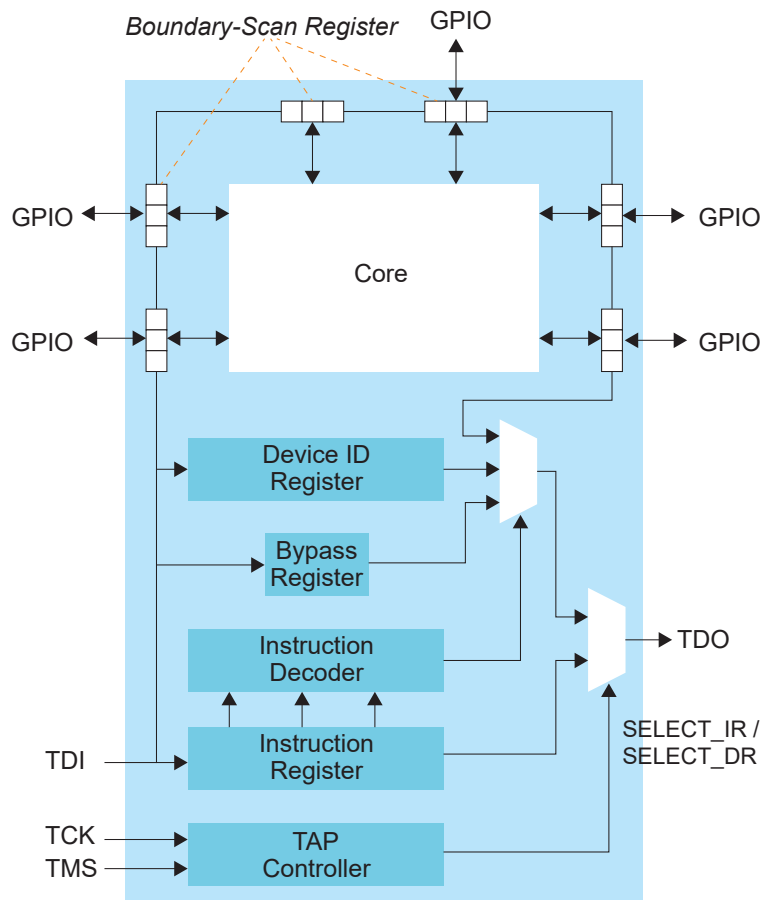

Table 1: Boundary -Scan Testing Support for Titanium FPGAs

| FPGA | Package | Supported |
|-------|---------|-----------|
| Ti35 | All | ✓ |
| Ti60 | All | ✓ |
| Ti85 | All | ✓ |
| Ti90 | All | ✓ |
| Ti120 | All | ✓ |
| Ti135 | All | ✓ |
| Ti165 | All | ✓ |
| Ti180 | All | ✓ |
| Ti240 | All | ✓ |
| Ti375 | All | ✓ |

JTAG Pins

The following table lists the pins required when performing BST on Titanium FPGAs. These pins provide access to the TAP controller.

Table 2: JTAG Pins

| Pin Name | Direction | Description |
|----------|-----------|--|
| TCK | Input | JTAG test clock input. The rising edge loads signals applied at the TAP input pins (TMS and TDI). The falling edge clocks out signals through the TAP TDO pin. |
| TMS | Input | JTAG test mode select. Mode select pin for the TAP controller. The value of TMS on the rising edge of TCK determines the next state in the TAP controller state machine. TMS is typically a weak pull-up; when external source does not drive it, the test logic perceives a logic 1. |
| TDI | Input | JTAG test data input. Data applied at this serial input goes to the instruction register or a test data register, depending on the state in the TAP controller. Typically, the signal applied at TDI changes states following the TCK's falling edge while the registers shift in the value received on the rising edge. TDI is typically a weak pull-up; when external source does not drive it, the test logic perceives a logic 1. |
| TDO | Output | JTAG test data output. The serial output from the instruction register or the test data register, depending on the state in the TAP controller. During shifting, data applied at TDI appears at TDO after several cycles of TCK determined by the length of the instruction register or test data register included in the serial path. The signal driven through TDO changes state following the falling edge of TCK. When no data is shifted through the device, TDO is set to an inactive drive state (e.g., high-impedance). |



Note: The JTAG pins (TCK, TDI, TDO, TMS) are not testable as these pins are not connected to the boundary-scan cells.

TAP Controller

The TAP Controller is controlled by the TMS pin and TCK pin, which controls the BST operation based on the TAP Controller State Machine. The status of the TMS pin on every rising edge of TCK brings the TAP Controller to a specific state.

Figure 2: IEEE Std. 1149.1 TAP Controller State Machine

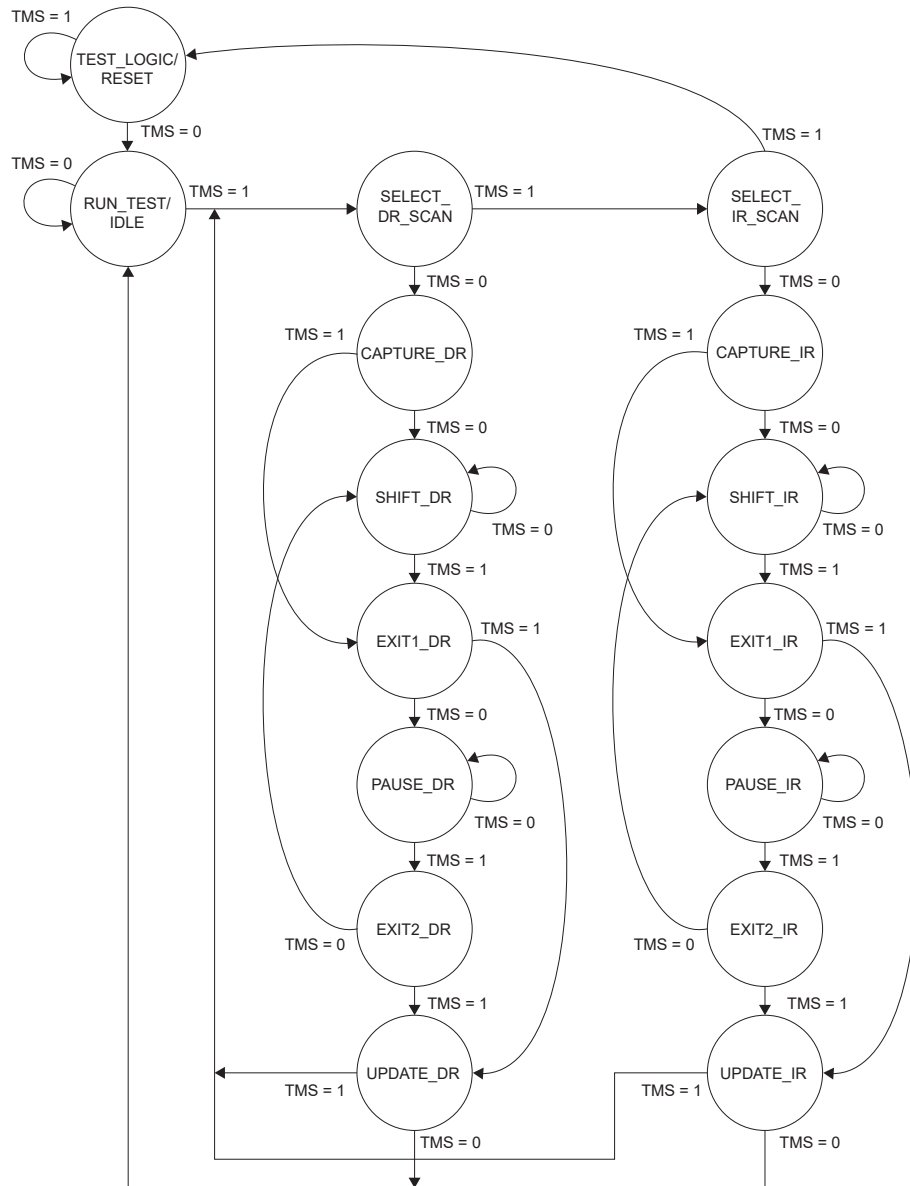

RESET State

The TAP Controller reaches this state when TMS is held high for five TCK pulses. This state is useful when the test logic needs to be disabled to perform Titanium FPGAs' regular operation. The TRST pin is not available in Titanium FPGAs. Pulse the TMS high for at least five times to disable the test logic or reset the TAP Controller.

RUN_TEST / IDLE State

TAP Controller state move from RESET state to this state when TMS is low. In Titanium FPGAs, you cannot use any instruction when the TAP controller is in this state.

SELECT_IR_SCAN to UPDATE_IR States

The instruction register is connected between the TDI pin and TDO pin to allow opcode instruction to be shifted into the instruction register from the TDI pin. Next, the opcode instruction is updated to enable TAP Controller to perform the corresponding actions.

SELECT_DR_SCAN to UPDATE_DR States

The data registers are connected between the TDI pin and TDO pin based on the opcode instruction updated in the instruction register.

Instruction Register

Titanium FPGAs support the following instruction registers.

Table 3: Titanium FPGA IEEE Std. 1149.1 Circuitry Instruction Register

| Register | Length (bits) | Description |
|-------------|---------------|---|
| Instruction | 5 | You can provide opcodes to the instruction register to determine the actions and select the data registers (device ID, bypass, or boundary-scan). |

Table 4: Titanium FPGA IEEE Std. 1149.1 BST Instructions

| Instruction | Opcode [4:0] | Description |
|----------------|--------------|--|
| IDCODE | 00011 | Selects the device ID register and returns the device ID of the Titanium FPGA through TDO. |
| BYPASS | 11111 | Selects the bypass register, thus allowing the TDI pin to be connected to the TDO by a 1-bit register. When the Titanium FPGA is connected to a daisy chain on the board to other JTAG devices, you can use this instruction if BST is not required on the Titanium FPGA. |
| EXTEST | 00000 | Selects the boundary-scan register. EXTEST allows off-chip circuitry testing by allowing the boundary-scan register to drive out the pin and monitor the data coming from the pin. |
| SAMPLE/PRELOAD | 00010 | PRELOAD allows the boundary-scan register to be preloaded with known data by shifting in the known data through the TDI pin before the EXTEST instruction is used. SAMPLE allows the boundary-scan register to sample the states of the pin and to be shifted out through TDO for analysis. |

Titanium Family JTAG Device IDs

The following table lists the Titanium JTAG device IDs.

Table 5: Titanium JTAG Device IDs

| FPGA | Package | JTAG Device ID |
|-------|--------------------------------|----------------|
| Ti35 | All | 0x10661A79 |
| Ti60 | All | 0x10660A79 |
| Ti85 | All | 0x006C2A79 |
| Ti90 | J361, J484, G400, G529 | 0x00691A79 |
| | L484 | 0x00688A79 |
| Ti120 | J361, J484, G400, G529 | 0x00692A79 |
| | L484 | 0x0068CA79 |
| Ti135 | All | 0x006C0A79 |
| Ti165 | All | 0x006A1A79 |
| Ti180 | M484 | 0x00680A79 |
| | J361, N484, J484D1, G400, G529 | 0x00690A79 |
| | L484 | 0x00684A79 |
| Ti240 | All | 0x006A2A79 |
| Ti375 | All | 0x006A0A79 |

Data Registers

The following table lists the available circuitry data registers.

Table 6: Titanium FPGA IEEE Std. 1149.1 Circuitry Data Registers

| Register | Length (bits) | Description |
|---------------|---------------|--|
| Device ID | 32 | Device ID register. Selected when the IDCODE instruction is provided to the instruction register. |
| Bypass | 1 | Bypass register. Selected when the BYPASS instruction is provided to the instruction register. |
| Boundary-scan | n | Boundary-scan register. Selected when the EXTEST or SAMPLE/PRELOAD instruction is provided to the instruction register. Refer to the BSDL file of the respective Titanium FPGA package to obtain its boundary-scan register length, n . |

Boundary-Scan Register

The boundary-scan register has data in, data OE, and data out signals connected to the FPGA core while buffer in, buffer OE, and buffer out signals are connected to the pad through the buffers. The Shift DR, Clock DR, and Update DR signals are the control signals generated by the TAP controller. The Clock DR signal supplies the clock to the capture register (flip-flops on the left). The Shift DR signal which controls the input multiplexers allows the register to capture the pin's states when low and shift the data when high. The Update DR signal supplies the clock to the update register (flip-flops on the right), which causes the data used to control the pin stored in the register. The Mode signal is generated by the instruction register to control the output multiplexers. The Mode signal is low during SAMPLE/PRELOAD instruction and high during EXTEST instruction.

HVIO Pins

The following figure shows the boundary-scan register on HVIO pins.

Figure 3: Titanium FPGA IEEE Std. 1149.1 Boundary-Scan Register on HVIO Pins

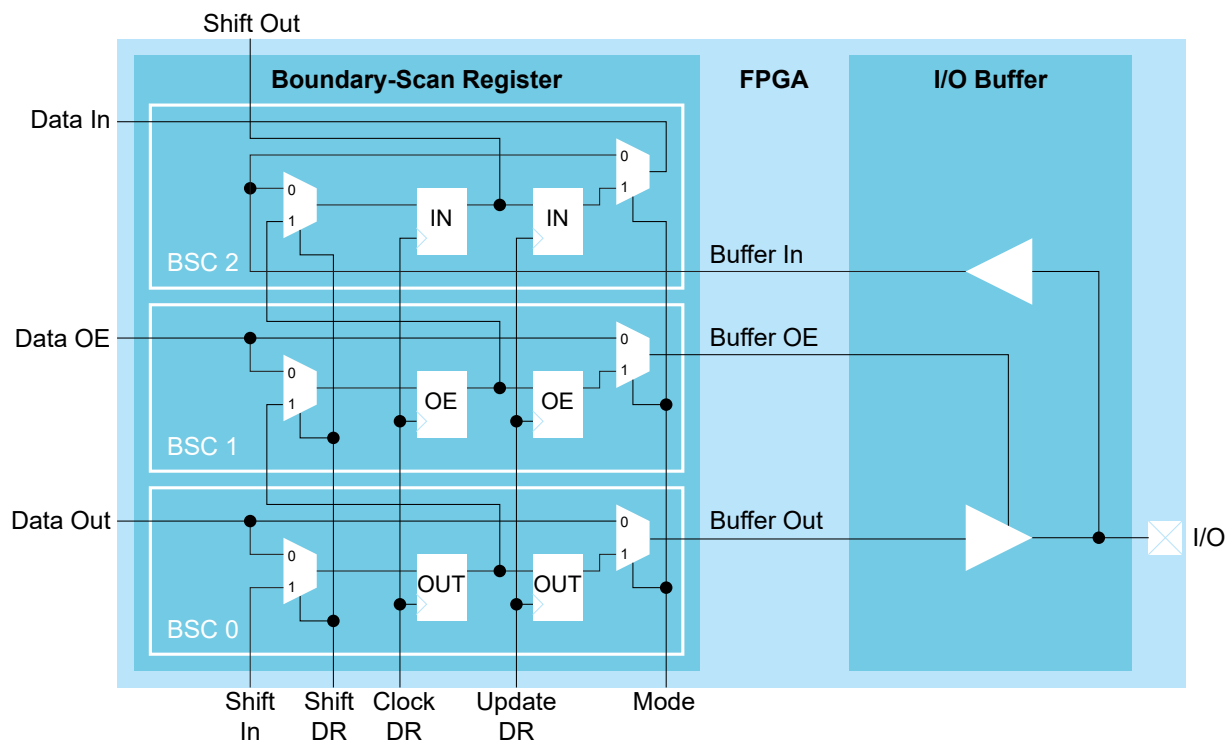

HSIO Pins

The following figure shows the boundary-scan register on HSIO pins.

Figure 4: Titanium FPGA IEEE Std. 1149.1 Boundary-Scan Register on HSIO Pins

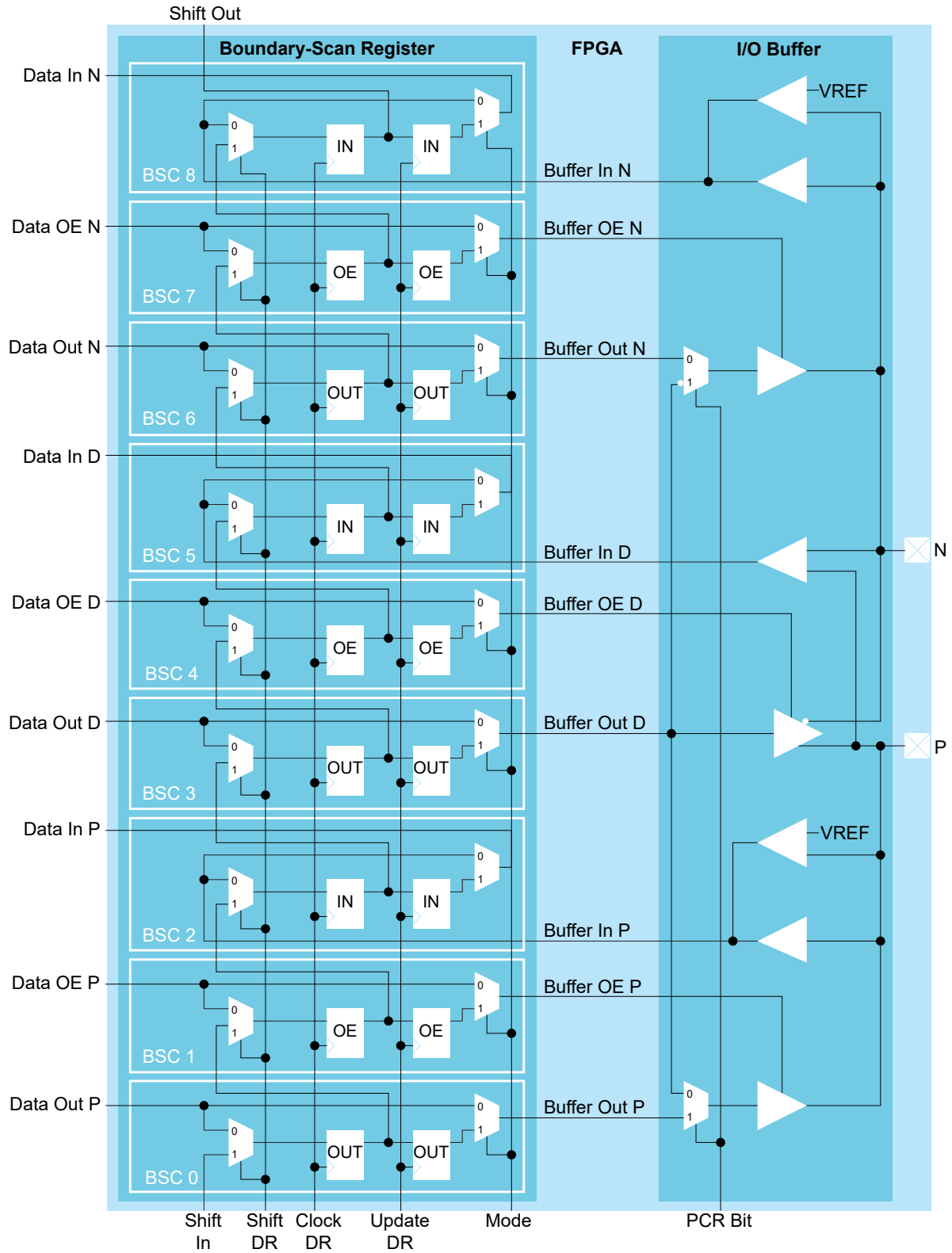

The signal path that passes from the pad through to the I/O buffer changes depending on the I/O standard you are using. The following figures show the paths for the supported standards. The blue color line indicates the signal path. The black lines are unused paths.

Figure 5: I/O Buffer Path for LVCMOS and LVTTL

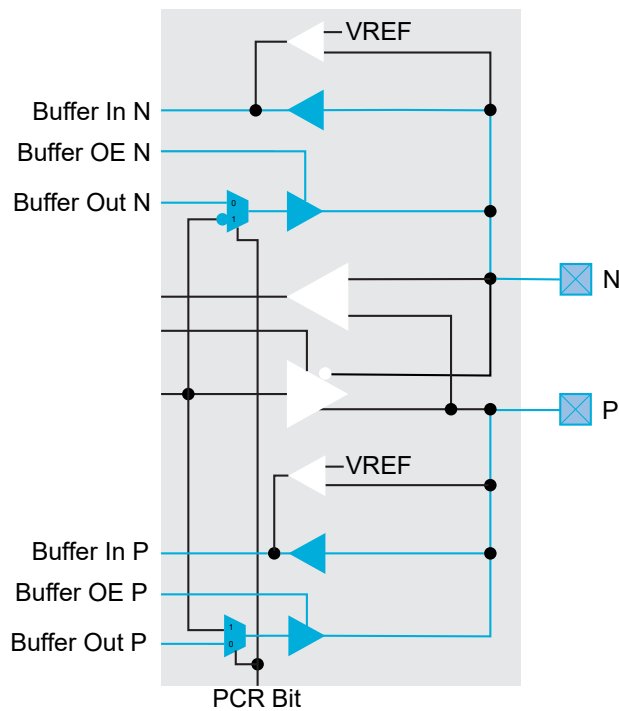

Figure 6: I/O Buffer Path for HSTL and SSTL

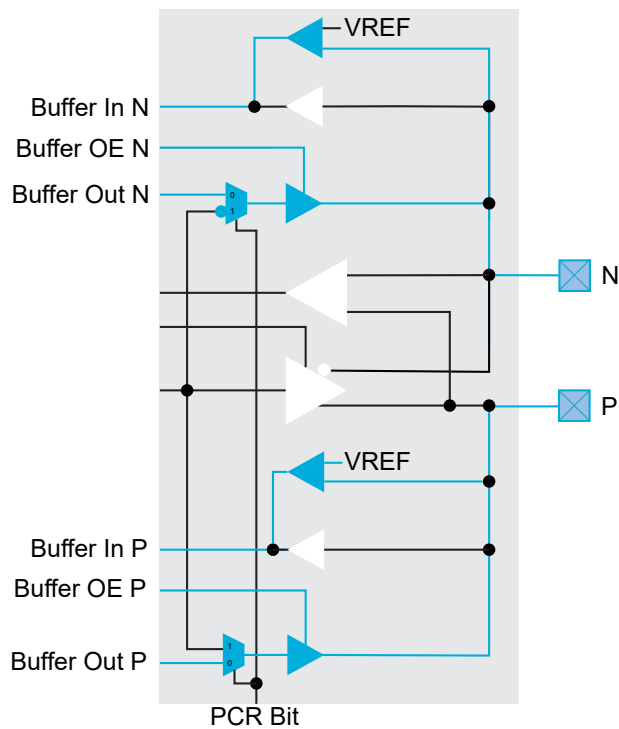
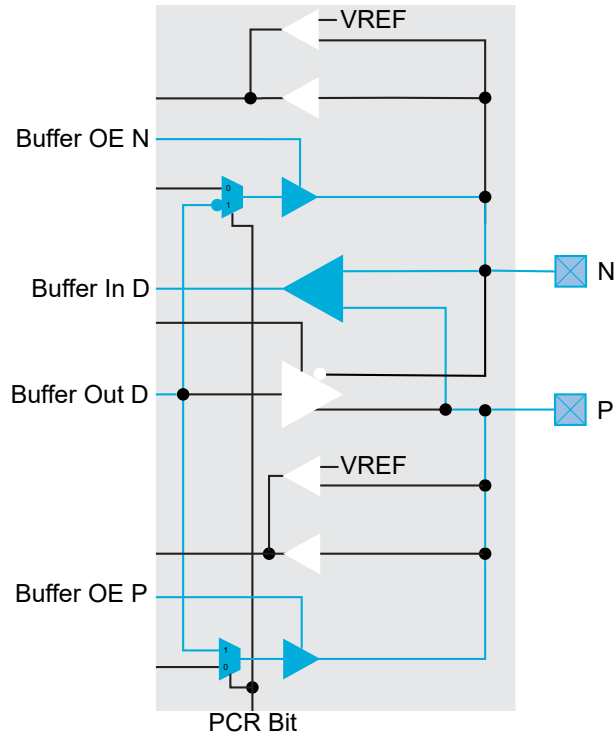
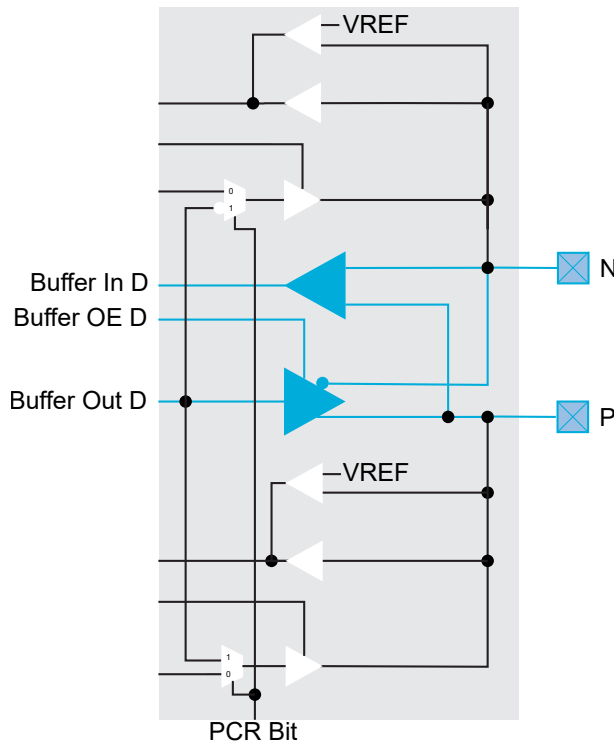

Figure 7: I/O Buffer Path for Differential HSTL and SSTL



Important: Both Buffer OE N and Buffer OE P must be controlled together. The signals to enable or disable the output buffers come from two different boundary-scan cells.

Figure 8: I/O Buffer Path for LVDS



Boundary-Scan Testing



Important: Disabling JTAG permanently disables the EXTEST and INTEST instructions. Therefore, Efinix® strongly recommends disabling JTAG **after** you have completed boundary scan testing.

However, if you use the JTAG DISABLE_EFUSE_ONLY option in the Efinity Programmer (available in the Efinity software v2024.2 and higher), you can still perform boundary scan testing after blowing the fuse. This option only disables the efuse instructions; other JTAG instructions are not affected.

The DISABLE_EFUSE_ONLY option is not available for Ti35 or Ti60 FPGAs.

HVIO Pins

Each HVIO pins consist of 3 boundary-scan cells which are used for input, output, and output enable.

During the boundary-scan testing on the unconfigured device, the boundary-scan register can control and monitor the input, output, and output enable states. The HVIO pins are in **weak pullup** mode.

During the boundary-scan testing on the configured device, the boundary-scan register can control and monitor the states of the enabled I/O buffer paths. The I/O buffer paths are determined by the GPIO modes in the Interface Designer. Unused HVIO pins are tri-stated and are configured in **weak pullup** mode. You can change the default mode to **weak pulldown** in the Interface Designer.

HSIO Pins

Each pair of HSIO pins consists of 9 boundary-scan cells. The input, output, and output enable are provided in every 3 boundary-scan cells.

During the boundary-scan testing on the unconfigured device, all the differential buffer paths are disabled. However, the boundary-scan register can control and monitor the input, output, and output enable states in the single-ended buffer paths. The HSIO pins are in **weak pullup** mode.

During the boundary-scan testing on the configured device, the boundary-scan register can control and monitor the states of the enabled I/O buffer paths. The I/O buffer paths are determined by the GPIO modes and the I/O standards in the Interface Designer. Unused HSIO pins are in **weak pullup** mode. You can change the default mode to **weak pulldown** in the Interface Designer. For the HSIO pin pair which is configured as differential I/O, you need to use the P pin to drive and monitor the differential signal. The same name of the P pin is also used in the BSDL file.

Dedicated Configuration Pins

The JTAG pins (TCK, TDI, TDO, and TMS) are not testable as these pins are not connected to the boundary-scan cells. The CONDONE and CRESET_N pins consist of observe-only cells which are able to monitor the signal states but are not able to drive the pins.

Dedicated MIPI Pins

The dedicated MIPI pins are not testable as these pins do not have boundary-scan cells.

Boundary-Scan Description Language

Efnix provides Boundary-Scan Description Language (BSDL) files to describe the IEEE Std. 1149.1 features of each Titanium FPGA. You can use the BSDL files to perform test program generation, boundary-scan testing, and failure analysis. Each Titanium FPGA has its dedicated BSDL file. You can obtain the BSDL files from the [Support Center](#) and the post-configuration BSDL file in your project's outflow. The Interface Designer creates the post-configuration BSDL file when you generate constraints.

Timing Parameters

Figure 9: Boundary-Scan Timing Waveform

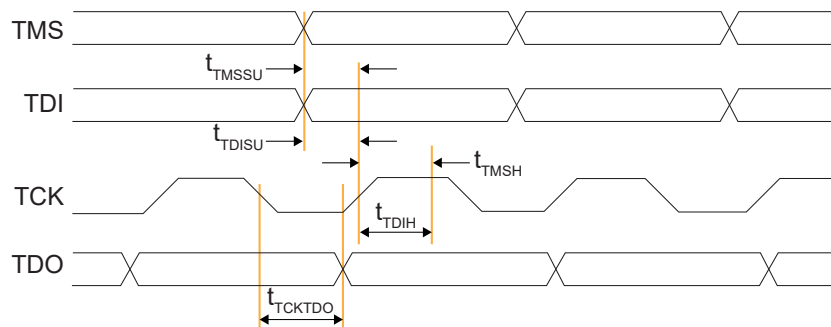

Learn more: Timing requirements are important to ensure a successful boundary-scan operation. Refer to the respective Titanium data sheet for timing specifications.

Revision History

Table 7: Revision History

| Date | Version | Description |
|---------------|---------|--|
| July 2025 | 1.9 | Added support for Ti85N576, Ti135N576, and Ti135N576D2F4. (DOC-2633) |
| January 2025 | 1.8 | Removed Trion and Topaz JTAG device IDs. |
| December 2024 | 1.7 | Important note added in Boundary-Scan Testing on page 12. (DOC-2220) |
| July 2024 | 1.6 | Updated JTAG IDs: (DOC-1851) <ul style="list-style-type: none"> • Ti85, Ti135, Ti375 |
| March 2024 | 1.5 | Removed JTAG IDs: (DOC-1761) <ul style="list-style-type: none"> • Ti90/Ti120: M361, M484, and F529 • Ti180: M361 and F529 |
| February 2024 | 1.4 | Added JTAG ID for devices Ti135, Ti240, and Ti375. (DOC-1590) |
| August 2023 | 1.3 | Added G400 package JTAG Device ID. (DOC-1385) |
| December 2022 | 1.2 | Added JTAG device IDCODE for J361, J484, G529 packages. (DOC-1084) |
| November 2022 | 1.1 | Added Boundary-Scan Register topic. (DOC-953) Added Boundary-Scan Testing topic. (DOC-953) Added explanation for post-configuration BSDL file. (DOC-953) |
| August 2022 | 1.0 | Initial release. |